

# 8Gb DDR4 SDRAM Specification

## Features

- Power supply
  - VDD = VDDQ = 1.2V  $\pm$  5%
  - VPP = 2.5V – 5% + 10%
- Data rate
  - 3200 Mbps (DDR4-3200)
  - 2933 Mbps (DDR4-2933)
  - 2666 Mbps (DDR4-2666)
  - 2400 Mbps (DDR4-2400)
  - 2133 Mbps (DDR4-2133)
  - 1866 Mbps (DDR4-1866)
  - 1600 Mbps (DDR4-1600)
- Package
  - 96-ball FBGA (A3F8GH40BBF)
  - Lead-free
- 8 internal banks  
2 groups of 4 banks each (x16)
- Differential clock inputs operation (CK\_t and CK\_c)
- Bi-directional differential data strobe (DQS\_t and DQS\_c)
- Asynchronous reset is supported (RESET\_n)
- ZQ calibration for Output driver by compare to external reference resistance (RZQ 240 ohm  $\pm$  1%)
- Nominal, park and dynamic On-die Termination (ODT)
- DLL aligns DQ and DQS transitions with CK transitions
- Commands entered on each positive CK edge
- CAS Latency (CL): 13, 15, 17, 19, 21, and 22 supported
- Additive Latency (AL) 0, CL-1, and CL-2 supported
- Burst Length (BL): 8 and 4 with on the fly supported
- CAS Write Latency (CWL): 9, 10, 11, 12, 14, 16, 18, and 20 supported
- Operating case temperature range  
TC = 0°C to +95°C (Commercial grade)
- Refresh cycles
  - Average refresh period
  - 7.8 $\mu$ s at 0°C  $\leq$  TC  $\leq$  +85°C
  - 3.9 $\mu$ s at +85°C < TC  $\leq$  +95°C
- Fine granularity refresh is supported
- Adjustable internal generation VREFDQ
- Pseudo Open Drain (POD) interface for data input/output
- Drive strength selected by MRS
- The high-speed data transfer by the 8 bits pre-fetch
- Temperature Controlled Refresh (TCR) mode is supported
- Low Power Auto Self Refresh (LPASR) mode is supported
- Self refresh abort is supported
- Programmable preamble is supported
- Write leveling is supported
- Command/Address latency (CAL) is supported
- Multipurpose register READ and WRITE capability
- Command Address Parity (CA Parity) for command address signal error detect and inform it to controller
- Write Cyclic Redundancy Code (CRC) for DQ error detect and inform it to controller during high-speed operation
- Data Bus Inversion (DBI) for Improve the power consumption and signal integrity of the memory interface
- Data mask (DM) for write data
- Per DRAM Addressability (PDA) for each DRAM can be set a different mode register value individually and has individual adjustment
- Gear down mode (1/2 and 1/4 rate) is supported
- hPPR and sPPR is supported
- Connectivity test (x16 only)
- Maximum power down mode for the lowest power consumption with no internal refresh activity
- JEDEC JESD-79-4 compliant

## Contents

Features .....	1
Contents .....	2
1. Ordering Information .....	3
2. Part Number .....	3
3. Pin Configurations .....	4
4. Input/Output Functional Description .....	5
5. Electrical Conditions .....	7
5.1 Absolute Maximum Ratings .....	7
5.2 Operating Temperature Condition .....	7
5.3 Recommended DC Operating Conditions .....	7
5.4 IDD and IDDQ Specification Parameters and Test conditions .....	8
6. Electrical Specifications .....	24
6.1 IDD Specifications .....	24
6.2 Input/Output Capacitance .....	26
6.3 Standard Speed Bins .....	28
6.4 Electrical Characteristics & AC Timing .....	36
7. DDR4 Function Matrix .....	51
8. Package Drawing .....	52
8.1 96-ball FBGA- x16 .....	52

## 1. Ordering Information

Part number	Die revision	Organization (words x bits)	Internal Banks	JEDEC speed bin (CL-nRCD-nRP)	Package
A3F8GH40BBF-MC	B	512 M x16	8	DDR4-3200 (22-22-22)	96-ball FBGA
A3F8GH40BBF-LY				DDR4-2933 (21-21-21)	
A3F8GH40BBF-KD				DDR4-2666 (19-19-19)	
A3F8GH40BBF-EE				DDR4-2400 (17-17-17)	

## 2. Part Number

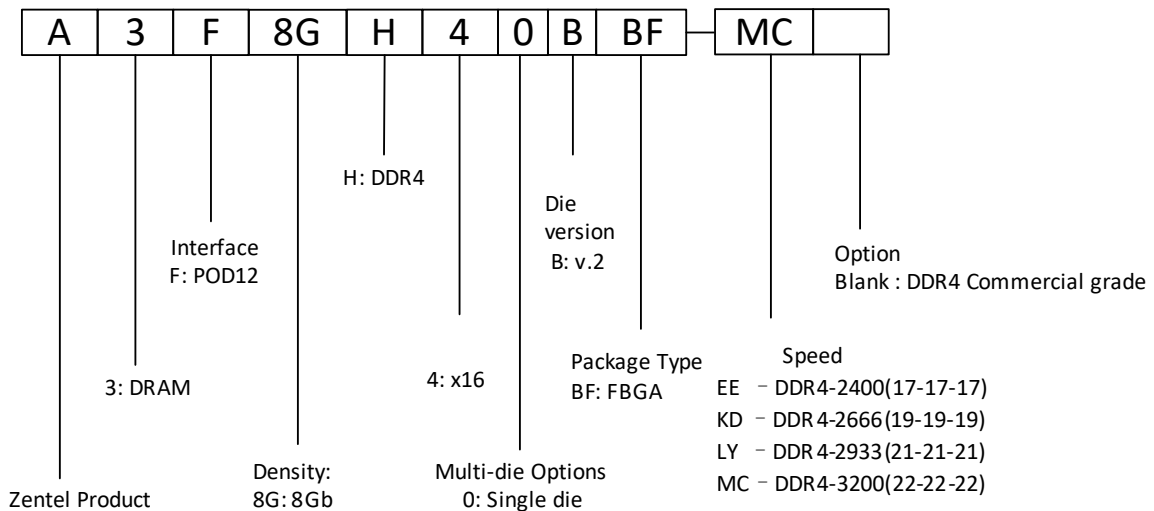

### 3. Pin Configurations

#### Pin Configurations (×16 configuration)

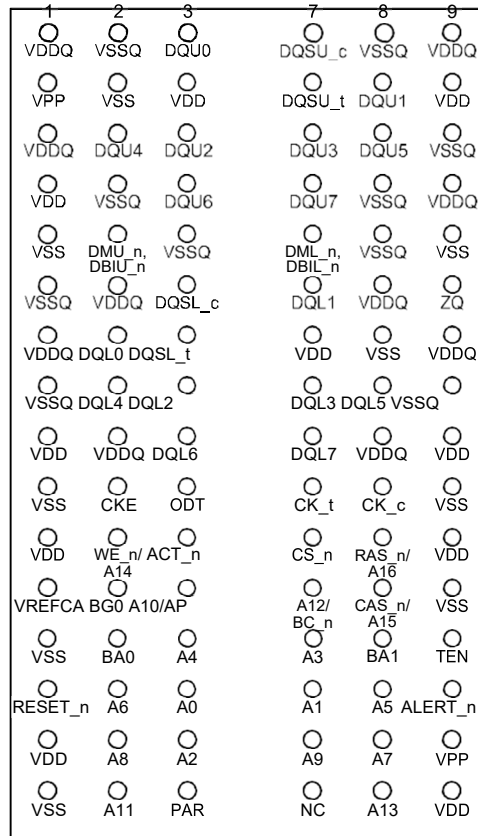

Pin name	Function	Pin name	Function
A0 to A14*2	Address inputs A10/AP: Auto precharge A12/BC_n: Burst chop	ODT*2	ODT control
BA0, BA1*2	Bank select	RESET_n*2	Active low asynchronous reset
BG0*2	Bank group input	PAR	Command and address parity
DQU0 to DQU7 DQL0 to DQL7	Data input/output	ALERT_n	Alert
DQSU, DQSU_n DQSL, DQSL_n	Differential data strobe	TEN	Connectivity test mode enable
CS_n*2	Chip select	VDD	Supply voltage for internal circuit
RAS_n/A16 CAS_n/A15 WE_n/A14*2	Command input	VSS	Ground for internal circuit
ACT_n*2	Activation command input	VDDQ	Supply voltage for DQ circuit
CKE*2	Clock enable	VSSQ	Ground for DQ circuit
CK_t, CK_c	Differential clock input	VREFCA	Reference voltage for CA
DMU_n, DML_n	Write data mask	ZQ	Reference pin for ZQ calibration
DBIU_n, DBIL_n	Data bus inversion	NC*1	No connection

Notes: 1. Not internally connected with die.

2. Input only pins (address, command, CKE, ODT and RESET\_n) do not supply termination.

## 4. Input/Output Functional Description

**Table 1: Input/Output function description**

Symbol	Type	Function
CK_t, CK_c	Input	Clock: CK_t and CK_c are differential clock inputs. All address and control input signals are sampled on the crossing of the positive edge of CK_t and negative edge of CK_c.
CKE	Input	Clock Enable: CKE HIGH activates, and CKE Low deactivates, internal clock signals and device input buffers and output drivers. Taking CKE Low provides Precharge Power-Down and Self-Refresh operation (all banks idle), or Active Power-Down (row Active in any bank). CKE is synchronous for Self-Refresh exit. After VREFCA and Internal DQ Vref have become stable during the power on and initialization sequence, they must be maintained during all operations (including Self-Refresh). CKE must be maintained high throughout read and write accesses. Input buffers, excluding CK_t,CK_c-ODT and CKE are disabled during power-down. Input buffers, excluding CKE, are disabled during Self-Refresh.
CS_n	Input	Chip Select: All commands are masked when CS_n is registered HIGH. CS_n provides for external Rank selection on systems with multiple Ranks. CS_n is considered part of the command code.
ODT	Input	On Die Termination: ODT (registered HIGH) enables RTT_NOM termination resistance internal to the DDR4 SDRAM. When enabled, ODT is only applied to each DQ, DQS_t, DQS_c and DM_n/DBI_n/ TDQS_t, NU/TDQS_c (When TDQS is enabled via Mode Register A11=1 in MR1) signal for x8 configurations. For x16 configuration ODT is applied to each DQ, DQSU_t, DQSU_c, DQSL_t, DQSL_c, DMU_n, and DML_n signal. The ODT pin will be ignored if MR1 is programmed to disable RTT_NOM.
ACT_n	Input	Activation Command Input: ACT_n defines the Activation command being entered along with CS_n. The input into RAS_n/A16, CAS_n/A15 and WE_n/A14 will be considered as Row Address A16, A15 and A14.
RAS_n/A16, CAS_n/A15, WE_n/A14	Input	Command Inputs: RAS_n/A16, CAS_n/A15 and WE_n/A14 (along with CS_n) define the command being entered. Those pins have multi function. For example, for activation with ACT_n Low, those are Addressing like A16, A15 and A14 but for non-activation command with ACT_n High, those are Command pins for Read, Write and other command defined in command truth table. A16 is not used on 4Gb part.
DM_n/DBI_n/TDQS_t, (DMU_n/DBIU_n), (DML_n/DBIL_n)	Input/Output	Input Data Mask and Data Bus Inversion: DM_n is an input mask signal for write data. Input data is masked when DM_n is sampled LOW coincident with that input data during a Write access. DM_n is sampled on both edges of DQS. DM is muxed with DBI function by Mode Register A10, A11, A12 setting in MR5. For x8 device, the function of DM or TDQS is enabled by Mode Register A11 setting in MR1. DBI_n is an input/output identifying whether to store/output the true or inverted data. If DBI_n is LOW, the data will be stored/output after inversion inside the DDR4 SDRAM and not inverted if DBI_n is HIGH. TDQS is only supported in X8
BG0 - BG1	Input	Bank Group Inputs: BG0 - BG1 define to which bank group an Active, Read, Write or Precharge command is being applied. BG0 also determines which mode register is to be accessed during a MRS cycle. x4/8 have BG0 and BG1 but x16 has only BG0
BA0 - BA1	Input	Bank Address Inputs: BA0 - BA1 define to which bank an Active, Read, Write or Precharge command is being applied. Bank address also determines which mode register is to be accessed during a MRS cycle.
A0 - A15	Input	Address Inputs: Provide the row address for ACTIVATE Commands and the column address for Read/ Write commands to select one location out of the memory array in the respective bank. (A10/AP, A12/ BC_n, RAS_n/A16, CAS_n/A15 and WE_n/A14 have additional functions, see other rows.The address inputs also provide the op-code during Mode Register Set commands.
A10 / AP	Input	Auto-precharge: A10 is sampled during Read/Write commands to determine whether Autoprecharge should be performed to the accessed bank after the Read/Write operation. (HIGH: Autoprecharge; LOW: no Autoprecharge). A10 is sampled during a Precharge command to determine whether the Precharge applies to one bank (A10 LOW) or all banks (A10 HIGH). If only one bank is to be precharged, the bank is selected by bank addresses.
A12 / BC_n	Input	Burst Chop: A12 / BC_n is sampled during Read and Write commands to determine if burst chop (on-the-fly) will be performed. (HIGH, no burst chop; LOW: burst chopped). See command truth table for details.
RESET_n	Input	Active Low Asynchronous Reset: Reset is active when RESET_n is LOW, and inactive when RESET_n is HIGH. RESET_n must be HIGH during normal operation. RESET_n is a CMOS rail to rail signal with DC high and low at 80% and 20% of V <sub>DD</sub> .
DQ	Input / Output	Data Input/ Output: Bi-directional data bus. If CRC is enabled via Mode register then CRC code is added at the end of Data Burst. Any DQ from DQ0~DQ3 may indicate the internal Vref level during test via Mode Register Setting MR4 A4=High. During this mode, RTT value should be set to Hi-Z. Refer to vendor specific datasheets to determine which DQ is used.
DQS_t, DQS_c, DQSU_t,DQSU_c, DQSL_t,DQSL_c	Input / Output	Data Strobe: output with read data, input with write data. Edge-aligned with read data, centered in write data. For the x16, DQSL corresponds to the data on DQL0-DQL7; DQSU corresponds to the data on DQU0-DQU7. The data strobe DQS_t, DQSL_t and DQSU_t are paired with differential signals DQS_c, DQSL_c and DQSU_c, respectively, to provide differential pair signaling to the system during reads and writes. DDR4 SDRAM supports differential data strobe only and does not support single-ended.

Symbol	Type	Function
TDQS_t, TDQS_c	Output	Termination Data Strobe: TDQS_t/TDQS_c is applicable for x8 DRAMs only. When enabled via Mode Register A11 = 1 in MR1, the DRAM will enable the same termination resistance function on TDQS_t/ TDQS_c that is applied to DQS_t/DQS_c. When disabled via mode register A11 = 0 in MR1, DM/DBI/ TDQS will provide the data mask function or Data Bus Inversion depending on MR5; A11,12,10and TDQS_c is not used. x4/x16 DRAMs must disable the TDQS function via mode register A11 = 0 in MR1.
PAR	Input	Command and Address Parity Input: DDR4 Supports Even Parity check in DRAMs with MR setting. Once it's enabled via Register in MR5, then DRAM calculates Parity with ACT_n,RAS_n,CAS_n/A15,WE_n/ A14,BG0-BG1,BA0-BA1,A15-A0. Input parity should maintain at the rising edge of the clock and at the same time with command & address with CS_n LOW
ALERT_n	Input/Output	Alert: It has multi functions such as CRC error flag, Command and Address Parity error flag as Output signal. If there is error in CRC, then Alert_n goes LOW for the period time interval and goes back HIGH. If there is error in Command Address Parity Check, then Alert_n goes LOW for relatively long period until on going DRAM internal recovery transaction to complete. During Connectivity Test mode, this pin works as input. Using this signal or not is dependent on system. In case of not connected as Signal, ALERT_n Pin must be bounded to VDD on board.
TEN	Input	Connectivity Test Mode Enable : Required on x16 devices and optional input on x4/x8 with densities equal to or greater than 8Gb. HIGH in this pin will enable Connectivity Test Mode operation along with other pins. It is a CMOS rail to rail signal with AC high and low at 80% and 20% of VDD. Using this signal or not is dependent on System. This pin may be DRAM internally pulled low through a weak pull-down resistor to VSS.
NC		No Connect: No internal electrical connection is present.
VDDQ	Supply	DQ Power Supply: 1.2 V +/- 0.06 V
VSSQ	Supply	DQ Ground
VDD	Supply	Power Supply: 1.2 V +/- 0.06 V
VSS	Supply	Ground
VPP	Supply	DRAM Activating Power Supply: 2.5V ( 2.375V min , 2.75V max)
VREFCA	Supply	Reference voltage for CA
ZQ	Supply	Reference Pin for ZQ calibration
<b>NOTE</b> : Input only pins (BG0-BG1,BA0-BA1, A0-A15, ACT_n, RAS_n, CAS_n/A15, WE_n/A14, CS_n, CKE, ODT, and RESET_n) do not supply termination.		

**Table 2: 8 Gb Addressing Table**

Configuration		512 Mb x16
Bank Address	# of Bank Groups	2
	BG Address	BG0
	Bank Address in a BG	BA0~BA1
Row Address		A0~A15
Column Address		A0~A9
Page size		2KB

## 5. Electrical Conditions

- All voltages are referenced to VSS (GND)
- Execute power-up and Initialization sequence before proper device operation is achieved.

### 5.1 Absolute Maximum Ratings

**Table 3 : Absolute Maximum Ratings**

Parameter	Symbol	Rating	Unit	Notes
Power supply voltage	VDD	-0.3 to +1.5	V	1, 3
Power supply voltage for output	VDDQ	-0.3 to +1.5	V	1, 3
DRAM activation power supply	VPP	-0.3 to +3.0	V	4
Input voltage	VIN	-0.3 to +1.5	V	1
Output voltage	VOUT	-0.3 to +1.5	V	1
Reference voltage	VREFCA	-0.3 to 0.6 x VDD	V	3
Storage temperature	Tstg	-55 to +100	°C	1, 2

- Notes: 1. Stresses greater than those listed under Absolute Maximum Ratings may cause permanent damage to the device. This is a stress rating only and functional operation of the device at these or any other conditions above those indicated in the operational sections of this specification is not implied. Exposure to absolute maximum rating conditions for extended periods may affect reliability.
2. Storage temperature is the case surface temperature on the center/top side of the DRAM.
  3. VDD and VDDQ must be within 300mV of each other at all times; and VREFCA must be no greater than  $0.6 \times VDDQ$ . When VDD and VDDQ are less than 500mV; VREFCA may be equal to or less than 300mV.
  4. VPP must be equal or greater than VDD/VDDQ at all times.

**Caution: Exposing the device to stress above those listed in Absolute Maximum Ratings could cause permanent damage. The device is not meant to be operated under conditions outside the limits described in the operational section of this specification. Exposure to Absolute Maximum Rating conditions for extended periods may affect device reliability.**

### 5.2 Operating Temperature Condition

**Table 4: Operating Temperature Condition**

Product grades	Parameter	Symbol	Rating	Unit	Notes
Commercial	Operating case temperature	TC	0 to +95	°C	1

- Note: 1. Operating temperature is the case surface temperature on the center/top side of the DRAM.

### 5.3 Recommended DC Operating Conditions

**Table 5: Recommended DC Operating Conditions (TC = 0°C to +85°C)**

Parameter	Symbol	min	typ	max	Unit	Notes
Supply voltage	VDD	1.14	1.2	1.26	V	1, 2, 3
Supply voltage for DQ	VDDQ	1.14	1.2	1.26	V	1, 2, 3
DRAM activating power	VPP	2.375	2.5	2.75	V	3
Ground	VSS	0	0	0	V	
Ground for DQ	VSSQ	0	0	0	V	

- Notes: 1. Under all conditions VDDQ must be less than or equal to VDD.  
2. VDDQ tracks with VDD. AC parameters are measured with VDD and VDDQ tied together.  
3. DC bandwidth is limited to 20 MHz.

## 5.4 IDD and IDDQ Specification Parameters and Test conditions

### 5.4.1 IDD, IPP and IDDQ Measurement Conditions

In this chapter, IDD, IPP and IDDQ measurement conditions such as test load and patterns are defined.

The figure Measurement Setup and Test Load for IDD and IDDQ Measurements shows the setup and test load for IDD, IPP and IDDQ measurements (Figure 1).

- IDD currents (such as IDD0, IDD0A, IDD1, IDD2N, IDD2NT, IDD2P, IDD2Q, IDD3N, IDD3P, IDD4R, IDD4W, IDD5B, IDD6N, IDD6E, IDD6A and IDD7) are measured as time-averaged currents with all VDD balls of the DDR4 SDRAM under test tied together. Any IPP or IDDQ current is not included in IDD currents.
- IPP currents have the same definition as IDD except that the current on the VPP supply is measured.
- IDDQ currents (such as IDDQ2NT and IDDQ4R) are measured as time-averaged currents with all VDDQ balls of the DDR4 SDRAM under test tied together. Any IDD current is not included in IDDQ currents.

Note:IDDQ values cannot be directly used to calculate I/O power of the DDR4 SDRAM. They can be used to support correlation of simulated I/O power to actual I/O power as outlined in correlation from simulated channel I/O power to actual channel I/O power supported by IDDQ measurement(Figure 2).

For IDD, IPP and IDDQ measurements, the following definitions apply:

- L and 0:  $V_{IN} \leq V_{IL(AC) \max}$
- H and 1:  $V_{IN} \geq V_{IH(AC) \min}$
- MID-LEVEL: defined as inputs are  $V_{REFCA} = V_{DD} / 2$
- Timings used for IDD, IPP and IDDQ measurement-loop patterns are provided in Table 6.
- Basic IDD, IPP and IDDQ measurement conditions are described in Table 7.

Note:The IDD, IPP and IDDQ measurement-loop patterns need to be executed at least one time before actual IDD or IDDQ measurement is started.

- Detailed IDD, IPP and IDDQ measurement-loop patterns are described in IDD0 Measurement-Loop Pattern table through IDD7 Measurement-Loop Pattern table(Table8~Table16).
- IDD Measurements are done after properly initializing the DDR4 SDRAM. This includes but is not limited to setting,
  - RON = RZQ/7 (34Ω in MR1);
  - Qoff = 0B (Output buffer enabled in MR1);
  - RTT\_Nom = RZQ/6 (40Ω in MR1); RTT\_WR = RZQ/2 (120Ω in MR2);
  - RTT\_PARK = Disable;
  - TDQS\_t feature disabled in MR1;
  - CRC disabled in MR2;
  - CA parity feature disabled in MR5;
  - Gear-down mode disabled in MR3;
  - Read/Write DBI disabled in MR5;
  - DM\_n disabled in MR5
- Define D = {CS\_n, ACT\_n, RAS\_n, CAS\_n, WE\_n} : = {H, L, L, L, L} ; apply BG/BA changes when directed.
- Define /D = {CS\_n, ACT\_n, RAS\_n, CAS\_n, WE\_n} : = {H, H, H, H, H}; apply BG/BA changes when directed.



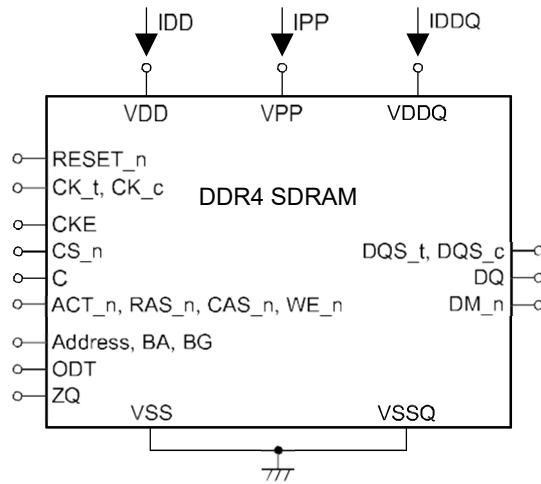

Figure 1: Measurement Setup and Test Load for IDD, IPP and IDDQ Measurements

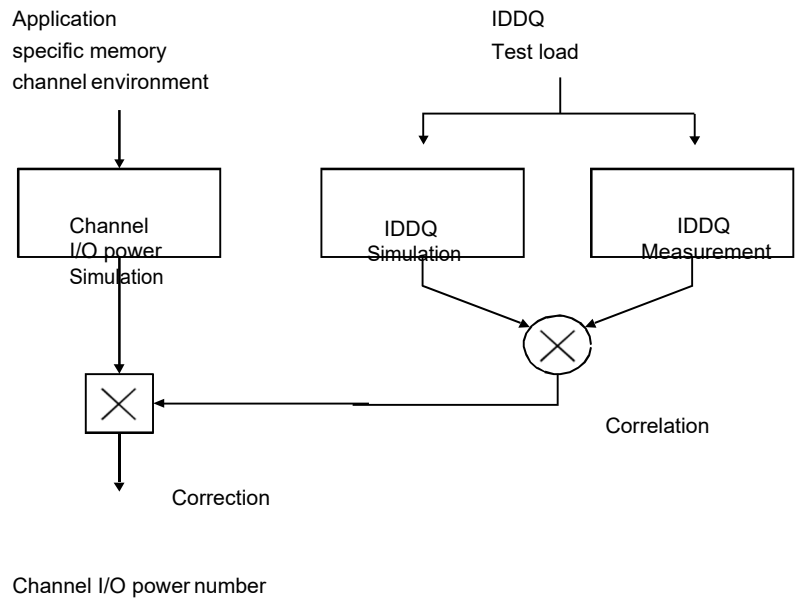

Figure 2: Correlation from Simulated Channel I/O Power to Actual Channel I/O Power Supported by IDDQ Measurement

### 5.4.2 Timings Used for IDD and IDDQ Measurement-LoopPatterns

**Table 6 : Timings Used for IDD and IDDQ Measurement-Loop Patterns**

Symbol		DDR4- 2400	DDR4- 2666	DDR4- 2933	DDR4- 3200	Unit
		17-17-17	19-19-19	21-21-21	22-22-22	
tCK		0.833	0.75	0.682	0.625	ns
CL		17	19	21	22	nCK
CWL		16	18	18	20	nCK
nRCD		17	19	20	22	nCK
nRC		56	62	67	74	nCK
nRAS		39	43	47	52	nCK
nRP		17	19	20	22	nCK
nFAW	x16	36	40	44	48	nCK
nRRDS	x16	7	7	8	9	nCK
nRRDL	x16	8	9	10	11	nCK
tCCD_S		4	4	4	4	nCK
tCCD_L		6	7	8	8	nCK
tWTR_S		3	4	4	4	nCK
tWTR_L		9	10	11	12	nCK
nRFC 8Gb		421	467	514	560	nCK

### 5.4.3 Basic IDD and IDDQ Measurement Conditions

Table 7 : Basic IDD, IPP and IDDQ Measurement Conditions

Symbol	Description
<b>IDD0</b>	<b>Operating One Bank Active-Precharge Current (AL=0)</b> CKE: H; External clock: on; tCK, nRC, nRAS, CL: see Table 6; BL: 8 <sup>1</sup> ; AL: 0; CS_n: H between ACT and PRE; Command, address, bank group address, bank address inputs: partially toggling according to Table 8; Data I/O: VDDQ; DM_n: stable at 1; Bank activity: cycling with one bank active at a time: 0,0,1,1,2,2,... (see Table 8); Output buffer and RTT: enabled in MR <sup>2</sup> ; ODT signal: stable at 0; Pattern details: see Table 8
<b>IDD0A</b>	<b>Operating One Bank Active-Precharge Current (AL=CL-1)</b> AL = CL-1, Other conditions: see IDD0
<b>IPP0</b>	<b>Operating One Bank Active-Precharge IPP Current</b> Same condition with IDD0
<b>IDD1</b>	<b>Operating One Bank Active-Read-Precharge Current(AL=0)</b> CKE: High; External clock: On; tCK, nRC, nRAS, nRCD, CL: see Table 6; BL: 8 <sup>1</sup> ; AL: 0; CS_n: H between ACT, RD and PRE; Command, address, bank group address, bank address inputs, data I/O: partially toggling according to Table 9; DM_n: stable at 1; Bank activity: cycling with one bank active at a time: 0,0,1,1,2,2,... (see Table 9); Output buffer and RTT: enabled in MR <sup>2</sup> ; ODT Signal: stable at 0; Pattern details: see Table 9
<b>IDD1A</b>	<b>Operating One Bank Active-Read-Precharge Current (AL=CL-1)</b> AL=CL-1, Other conditions : see IDD1
<b>IPP1</b>	<b>Operating One Bank Active-Read-Precharge IPPCurrent</b> Same condition with IDD1
<b>IDD2N</b>	<b>Precharge Standby Current (AL=0)</b> CKE: H; External clock: on; tCK, CL: see Table 6; BL: 8 <sup>1</sup> ; AL: 0; CS_n: stable at 1; Command, address, bank group address, bank address Inputs: partially toggling according to Table 10; data I/O: VDDQ; DM_n: stable at 1; bank activity: all banks closed; output buffer and RTT: enabled in MR <sup>2</sup> ; ODT signal: stable at 0; pattern details: see Table 10
<b>IDD2NA</b>	<b>Precharge Standby Current (AL=CL-1)</b> Same condition with IDD2N
<b>IPP2N</b>	<b>Precharge Standby IPP Current</b> AL = CL-1, Other conditions: see IDD2N
<b>IDD2NT</b>	<b>Precharge Standby ODT Current</b> CKE: H; External clock: on; tCK, CL: see Table 6; BL: 8 <sup>1</sup> ; AL: 0; CS_n: stable at 1; Command, address, bank group address, bank address Inputs: partially toggling according to Table 11; data I/O: VSSQ; DM_n: stable at 1; bank activity: all banks closed; output buffer and RTT: enabled in MR <sup>2</sup> ; ODT signal: toggling according to Table 11; pattern details: see Table 11
<b>IDDQ2NT (Optional)</b>	<b>Precharge Standby ODT IDDQ Current</b> Same definition like for IDD2NT, however measuring IDDQ current instead of IDD current
<b>IDD2NL</b>	<b>Precharge Standby Current with CAL enabled</b> Same definition like for IDD2N, CAL enabled <sup>3</sup>
<b>IDD2NG</b>	<b>Precharge Standby Current with Gear Down mode enabled</b> Same definition like for IDD2N, Gear Down mode enabled <sup>3,5</sup>
<b>IDD2ND</b>	<b>Precharge Standby Current with DLL disabled</b> Same definition like for IDD2N, DLL disabled <sup>3</sup>
<b>IDD2N_par</b>	<b>Precharge Standby Current with CA parity enabled</b> Same definition like for IDD2N, CA parity enabled <sup>3</sup>
<b>IDD2P</b>	<b>Precharge Power-Down Current</b> CKE: Low; External clock: on; tCK, CL: see Table 6; BL: 8 <sup>1</sup> ; AL: 0; CS_n: stable at 1; Command, address, bank group address, bank address inputs: stable at 0; data I/O: VDDQ; DM_n: stable at 1; bank activity: all banks closed; output buffer and RTT: enabled in MR <sup>2</sup> ; ODT signal: stable at 0
<b>IPP2P</b>	<b>Precharge Power-Down IPP Current</b> Same condition with IDD2P
<b>IDD2Q</b>	<b>Precharge Quiet Standby Current</b> CKE: H; External clock: On; tCK, CL: see Table 6; BL: 8 <sup>1</sup> ; AL: 0; CS_n: stable at 1; Command, address, bank group address, bank address Inputs: stable at 0; data I/O: VDDQ; DM_n: stable at 1; bank activity: all banks closed; output buffer and RTT: enabled in MR <sup>2</sup> ; ODT signal: stable at 0

Symbol	Description
<b>IDD3N</b>	<b>Active Standby Current</b> CKE: H; External clock: on; tCK, CL: see Table 6; BL: 8 <sup>1</sup> ; AL: 0; CS_n: stable at 1; Command, address, bank group address, bank address Inputs: partially toggling according to Table 10; data I/O: VDDQ; DM_n: stable at 1; bank activity: all banks open; output buffer and RTT: enabled in MR <sup>2</sup> ; ODT signal: stable at 0; pattern details: see Table 10
<b>IDD3NA</b>	<b>Active Standby Current (AL=CL-1)</b> Same condition with IDD3N
<b>IPP3N</b>	<b>Active Standby IPP Current</b> AL = CL-1, Other conditions: see IDD3N
<b>IDD3P</b>	<b>Active Power-Down Current</b> CKE: L; External clock: on; tCK, CL: see Table 6; BL: 8 <sup>1</sup> ; AL: 0; CS_n: stable at 1; Command, address, bank group address, bank address inputs: stable at 0; data I/O: VDDQ; DM_n: stable at 1; bank activity: all banks open; output buffer and RTT: enabled in MR <sup>2</sup> ; ODT signal: stable at 0
<b>IPP3P</b>	<b>Active Power-Down IPP Current</b> Same condition with IDD3P
<b>IDD4R</b>	<b>Operating Burst Read Current</b> CKE: H; External clock: on; tCK, CL: see Table 6; BL: 8 <sup>1</sup> ; AL: 0; CS_n: H between RD; Command, address, Bank group address, Bank address Inputs: partially toggling according to Table 12; data I/O: seamless read data burst with different data between one burst and the next one according to Table 12; DM_n: stable at 1; Bank activity: all Banks open, RD commands cycling through banks: 0,0,1,1,2,2,... (see Table 12); output buffer and RTT: enabled in MR <sup>2</sup> ; ODT signal: stable at 0; pattern details: see Table 12
<b>IDD4RA</b>	<b>Operating Burst Read Current (AL=CL-1)</b> AL = CL-1, Other conditions: see IDD4R
<b>IDD4RB</b>	<b>Operating Burst Read Current with Read DBI</b> Read DBI enabled <sup>3</sup> , Other conditions: see IDD4R
<b>IPP4R</b>	<b>Operating Burst Read IPP Current</b> Same condition with IDD4R
<b>IDD4QR (Optional)</b>	<b>Operating Burst Read IDDQ Current</b> Same definition like for IDD4R, however measuring IDDQ current instead of IDD current
<b>IDD4QRB (Optional)</b>	<b>Operating Burst Read IDDQ Current with Read DBI</b> Same definition like for IDD4RB, however measuring IDDQ current instead of IDD current
<b>IDD4W</b>	<b>Operating Burst Write Current</b> CKE: H; External clock: on; tCK, CL: see Table 6; BL: 8 <sup>1</sup> ; AL: 0; CS_n: H between WR; command, address, bank group address, bank address inputs: partially toggling according to Table 13; data I/O: seamless write data burst with different data between one burst and the next one according to Table 13; DM_n: stable at 1; bank activity: all banks open, WR commands cycling through banks: 0,0,1,1,2,2,... (see Table 13); output buffer and RTT: enabled in MR <sup>2</sup> ; ODT signal: stable at H; pattern details: see Table 13
<b>IDD4WA</b>	<b>Operating Burst Write Current (AL=CL-1)</b> AL = CL-1, Other conditions: see IDD4W
<b>IDD4WB</b>	<b>Operating Burst Write Current with Write DBI</b> Write DBI enabled <sup>3</sup> , Other conditions: see IDD4W
<b>IDD4WC</b>	<b>Operating Burst Write Current with Write CRC</b> Write CRC enabled <sup>3</sup> , Other conditions: see IDD4W
<b>IDD4W_par</b>	<b>Operating Burst Write Current with CA Parity</b> CA Parity enabled <sup>3</sup> , Other conditions: see IDD4W
<b>IPP4W</b>	<b>Operating Burst Write IPP Current</b> Same condition with IDD4W
<b>IDD5B</b>	<b>Burst Refresh Current (1X REF)</b> CKE: H; External clock: on; tCK, CL, nRFC: see Table 6; BL: 8 <sup>1</sup> ; AL: 0; CS_n: H between REF; Command, address, bank group address, bank address Inputs: partially toggling according to Table 15; data I/O: VDDQ; DM_n: stable at 1; bank activity: REF command every nRFC (Table 15); output buffer and RTT: enabled in MR <sup>2</sup> ; ODT signal: stable at 0; pattern details: see Table 15
<b>IPP5B</b>	<b>Burst Refresh IPP Current (1X REF)</b> Same condition with IDD5B

Symbol	Description
IDD5F2	<b>Burst Refresh Current (2X REF)</b> tRFC=tRFC_x2, Other conditions: see IDD5B
IPP5F2	<b>Burst Refresh Write IPP Current (2X REF)</b> Same condition with IDD5F2
IDD5F4	<b>Burst Refresh Current (4X REF)</b> tRFC=tRFC_x4, Other conditions: see IDD5B
IPP5F4	<b>Burst Refresh Write IPP Current (4X REF)</b> Same condition with IDD5F4
IDD6N	<b>Self-Refresh Current: Normal Temperature Range</b> TC: 0 to 85°C; LP ASR: Normal <sup>4</sup> ; CKE: L; External clock: off; CK_t and CK_c: L; CL: see Table 6; BL: 8 <sup>1</sup> ; AL: 0; CS_n, command, address, bank group address, bank address, data I/O: H; DM_n: stable at 1; bank activity: self-refresh operation; Output buffer and RTT: enabled in MR <sup>2</sup> ; ODT signal: MID-LEVEL
IPP6N	<b>Self-Refresh IPP Current: Normal Temperature Range</b> Same condition with IDD6N
IDD6E	<b>Self-Refresh Current: Extended Temperature Range</b> TC: 0 to 95°C; Low Power Auto Self Refresh (LP ASR): Extended <sup>4</sup> ; CKE: L; External clock: off; CK_t and CK_c: L; CL: see Table 6; BL: 8 <sup>1</sup> ; AL: 0; CS_n, command, address, bank group address, bank address, data I/O: H; DM_n: stable at 1; bank activity: Extended temperature self-refresh operation; Output buffer and RTT: enabled in MR <sup>2</sup> ; ODT signal: MID-LEVEL
IPP6E	<b>Self-Refresh IPP Current: Extended Temperature Range</b> Same condition with IDD6E
IDD6R	<b>Self-Refresh Current: Reduced Temperature Range</b> TC: 0 to 45°C; LP ASR: Reduced <sup>4</sup> ; CKE: L; External clock: off; CK_t and CK_c: L; CL: see Table 6; BL: 8 <sup>1</sup> ; AL: 0; CS_n, command, address, bank group address, bank address, data I/O: H; DM_n: stable at 1; bank activity: Reduced temperature self-refresh operation; Output buffer and RTT: enabled in MR <sup>2</sup> ; ODT signal: MID-LEVEL
IPP6R	<b>Self-Refresh IPP Current: Reduced Temperature Range</b> Same condition with IDD6R
IDD6A	<b>Auto Self-Refresh Current</b> TC: 0 to 95°C; LP ASR: Auto <sup>4</sup> ; CKE: L; External clock: off; CK_t and CK_c: L; CL: see Table 6; BL: 8 <sup>1</sup> ; AL: 0; CS_n, command, address, bank group address, bank address, data I/O: H; DM_n: stable at 1; bank activity: auto self-refresh operation; Output buffer and RTT: enabled in MR <sup>2</sup> ; ODT signal: MID-LEVEL
IPP6A	<b>Auto Self-Refresh IPP Current</b> Same condition with IDD6A
IDD7	<b>Operating Bank Interleave Read Current</b> CKE: H; External clock: on; tCK, nRC, nRAS, nRCD, nRRD, nFAW, CL: see Table 6; BL: 8 <sup>1</sup> ; AL: CL-1; CS_n: H between ACT and RDA; Command, address, bank group address, bank address Inputs: partially toggling according to Table 16; data I/O: read data bursts with different data between one burst and the next one according to Table 16; DM_n: stable at 1; bank activity: two times interleaved cycling through banks (0, 1, ...7) with different addressing, see Table 16; output buffer and RTT: enabled in MR <sup>2</sup> ; ODT signal: stable at 0; pattern details: see Table 16
IPP7	<b>Operating Bank Interleave Read IPP Current</b> Same condition with IDD7
IDD8	<b>Maximum Power Down Current</b> TBD
IPP8	<b>Maximum Power Down IPP Current</b> Same condition with IDD8

- Notes: 1. Burst Length: BL8 fixed by MRS: MR0 bits A[1,0] = [0,0].
2. MR: Mode Register
- Output buffer enable:
    - set MR1 bit A12 = 0: Qoff = output buffer enabled
    - and MR1 bits A[2, 1] = [0,0]: output driver impedance control = RZQ/7
  - RTT\_Nom enable:
    - set MR1 bits A[10:8] = [0,1,1]: RTT\_Nom = RZQ/6
  - RTT\_WR enable:
    - set MR2 bits A[11:9] = [0,0,1]: RTT\_WR = RZQ/2
  - RTT\_PARK disable:
    - set MR5 bits A[8:6] = [0,0,0]
3. CAL enabled:
  - set MR4 bits A[8:6] = [0,0,1]: 1600MT/s;
  - [0,1,0]: 1866MT/s, 2133MT/s;
  - [0,1,1]: 2400MT/s
  - [0,1,1]: 2666MT/s
- Gear down mode enabled:
  - set MR3 bit A3 = 1: 1/4 Rate
- DLL disabled:
  - set MR1 bit A0 = 0
- CA parity enabled:
  - set MR5 bits A[2:0] = [0,0,1]: 1600MT/s, 1866MT/s, 2133MT/s
  - [0,1,0]: 2400MT/s, 2666MT/s
- Read DBI enabled:
  - set MR5 bit A12 = 1
- Write DBI enabled:
  - set: MR5 bit A11 = 1
4. Low Power Auto Self-Refresh (LP ASR)
  - set MR2 bits A[7:6] = [0,0]: Normal
  - [0,1]: Reduced temperature range
  - [1,0]: Extended temperature range
  - [1,1]: Auto self-refresh

**Table 8: IDD0, IDD0A and IPP0 Measurement-Loop Pattern<sup>1</sup>**

CK_t/CK_c	CKE	Sub-Loop	Cycle Number	Command	CS_n	ACT_n	RAS_n	CAS_n/A15	WE_n/A14	ODT	C[2:0] <sup>3</sup>	BG[1:0] <sup>2</sup>	BA[1:0]	A12/BC_n	A[13,11]	A[10]/AP	A[9:7]	A[6:3]	A[2:0]	Data <sup>4</sup>				
toggling	Static High	0	0	ACT	0	0	0	0	0	0	0	0	0	0	0	0	0	0	0	0	-			
			1,2	D, D	1	0	0	0	0	0	0	0	0	0	0	0	0	0	0	0	0	0	-	
			3,4	D#, D#	1	1	1	1	1	1	0	0	0	3 <sup>2</sup>	3	0	0	0	7	F	0	0	-	
			...	repeat pattern 1...4 until nRAS - 1, truncate if necessary																				
			nRAS	PRE	0	1	0	1	0	0	0	0	0	0	0	0	0	0	0	0	0	0	0	-
			...	repeat pattern 1...4 until nRC - 1, truncate if necessary																				
		1	1*nRC	repeat Sub-Loop 0, use BG[1:0] <sup>2</sup> = 1, BA[1:0] = 1 instead																				
		2	2*nRC	repeat Sub-Loop 0, use BG[1:0] <sup>2</sup> = 0, BA[1:0] = 2 instead																				
		3	3*nRC	repeat Sub-Loop 0, use BG[1:0] <sup>2</sup> = 1, BA[1:0] = 3 instead																				
		4	4*nRC	repeat Sub-Loop 0, use BG[1:0] <sup>2</sup> = 0, BA[1:0] = 1 instead																				
		5	5*nRC	repeat Sub-Loop 0, use BG[1:0] <sup>2</sup> = 1, BA[1:0] = 2 instead																				
		6	6*nRC	repeat Sub-Loop 0, use BG[1:0] <sup>2</sup> = 0, BA[1:0] = 3 instead																				
		7	7*nRC	repeat Sub-Loop 0, use BG[1:0] <sup>2</sup> = 1, BA[1:0] = 0 instead																				
		8	8*nRC	repeat Sub-Loop 0, use BG[1:0] <sup>2</sup> = 2, BA[1:0] = 0 instead																				
		9	9*nRC	repeat Sub-Loop 0, use BG[1:0] <sup>2</sup> = 3, BA[1:0] = 1 instead																				
10	10*nRC	repeat Sub-Loop 0, use BG[1:0] <sup>2</sup> = 2, BA[1:0] = 2 instead																						
11	11*nRC	repeat Sub-Loop 0, use BG[1:0] <sup>2</sup> = 3, BA[1:0] = 3 instead																						
12	12*nRC	repeat Sub-Loop 0, use BG[1:0] <sup>2</sup> = 2, BA[1:0] = 1 instead																						
13	13*nRC	repeat Sub-Loop 0, use BG[1:0] <sup>2</sup> = 3, BA[1:0] = 2 instead																						
14	14*nRC	repeat Sub-Loop 0, use BG[1:0] <sup>2</sup> = 2, BA[1:0] = 3 instead																						
15	15*nRC	repeat Sub-Loop 0, use BG[1:0] <sup>2</sup> = 3, BA[1:0] = 0 instead																						

- NOTE :**
1. DQS\_t, DQS\_c are VDDQ.
  2. BG1 is don't care for x16 device
  3. C[2:0] are used only for 3DS device
  4. DQ signals are VDDQ.

For x4 and x8 only

**Table 9: IDD1, IDD1A and IPP1 Measurement-Loop Pattern<sup>1</sup>**

CK_t, CK_c	CKE	Sub-Loop	Cycle Number	Command	CS_n	ACT_n	RAS_n	CAS_n/A15	WE_n/A14	ODT	C[2:0] <sup>3</sup>	BG[1:0] <sup>2</sup>	BA[1:0]	A12/BC_n	A[13,11]	A[10]/AP	A[9:7]	A[6:3]	A[2:0]	Data <sup>4</sup>			
toggling	Static High	0	0	ACT	0	0	0	0	0	0	0	0	0	0	0	0	0	0	0	0	-		
			1, 2	D, D	1	0	0	0	0	0	0	0	0	0	0	0	0	0	0	0	0	-	
			3, 4	D#, D#	1	1	1	1	1	1	0	0	3 <sup>2</sup>	3	0	0	0	7	F	0	-		
			...	repeat pattern 1...4 until nRCD - AL - 1, truncate if necessary																			
			nRCD -AL	RD	0	1	1	0	1	0	0	0	0	0	0	0	0	0	0	0	0	0	D0=00, D1=FF D2=FF, D3=00 D4=FF, D5=00 D6=00, D7=FF
			...	repeat pattern 1...4 until nRAS - 1, truncate if necessary																			
			nRAS	PRE	0	1	0	1	0	0	0	0	0	0	0	0	0	0	0	0	0	0	-
			...	repeat pattern 1...4 until nRC - 1, truncate if necessary																			
			1*nRC + 0	ACT	0	0	0	1	1	0	0	1	1	0	0	0	0	0	0	0	0	0	-
			1*nRC + 1, 2	D, D	1	0	0	0	0	0	0	0	0	0	0	0	0	0	0	0	0	0	-
		1*nRC + 3, 4	D#, D#	1	1	1	1	1	0	0	0	3 <sup>2</sup>	3	0	0	0	7	F	0	-			
		...	repeat pattern nRC + 1...4 until 1*nRC + nRAS - 1, truncate if necessary																				
		1*nRC + nRCD - AL	RD	0	1	1	0	1	0	0	1	1	0	0	0	0	0	0	0	0	0	D0=FF, D1=00 D2=00, D3=FF D4=00, D5=FF D6=FF, D7=00	
		...	repeat pattern 1...4 until nRAS - 1, truncate if necessary																				
		1*nRC + nRAS	PRE	0	1	0	1	0	0	0	0	0	0	0	0	0	0	0	0	0	0	-	
		...	repeat nRC + 1...4 until 2*nRC - 1, truncate if necessary																				
		2	2*nRC	repeat Sub-Loop 0, use BG[1:0] <sup>2</sup> = 0, BA[1:0] = 2 instead																			
		3	3*nRC	repeat Sub-Loop 1, use BG[1:0] <sup>2</sup> = 1, BA[1:0] = 3 instead																			
		4	4*nRC	repeat Sub-Loop 0, use BG[1:0] <sup>2</sup> = 0, BA[1:0] = 1 instead																			
		5	5*nRC	repeat Sub-Loop 1, use BG[1:0] <sup>2</sup> = 1, BA[1:0] = 2 instead																			
		6	6*nRC	repeat Sub-Loop 0, use BG[1:0] <sup>2</sup> = 0, BA[1:0] = 3 instead																			
		8	7*nRC	repeat Sub-Loop 1, use BG[1:0] <sup>2</sup> = 1, BA[1:0] = 0 instead																			
		9	9*nRC	repeat Sub-Loop 1, use BG[1:0] <sup>2</sup> = 2, BA[1:0] = 0 instead																			
		10	10*nRC	repeat Sub-Loop 0, use BG[1:0] <sup>2</sup> = 3, BA[1:0] = 1 instead																			
		11	11*nRC	repeat Sub-Loop 1, use BG[1:0] <sup>2</sup> = 2, BA[1:0] = 2 instead																			
		12	12*nRC	repeat Sub-Loop 0, use BG[1:0] <sup>2</sup> = 3, BA[1:0] = 3 instead																			
		13	13*nRC	repeat Sub-Loop 1, use BG[1:0] <sup>2</sup> = 2, BA[1:0] = 1 instead																			
		14	14*nRC	repeat Sub-Loop 0, use BG[1:0] <sup>2</sup> = 3, BA[1:0] = 2 instead																			
15	15*nRC	repeat Sub-Loop 1, use BG[1:0] <sup>2</sup> = 2, BA[1:0] = 3 instead																					
16	16*nRC	repeat Sub-Loop 0, use BG[1:0] <sup>2</sup> = 3, BA[1:0] = 0 instead																					

**NOTE :**

1. DQS\_t, DQS\_c are used according to RD Commands, otherwise VDDQ
2. BG1 is don't care for x16 device
3. C[2:0] are used only for 3DS device
4. Burst Sequence driven on each DQ signal by Read Command. Outside burst operation, DQ signals are VDDQ.



**Table 10: IDD2N, IDD2NA, IDD2NL, IDD2NG, IDD2N\_par, IPP2, IDD3N, IDD3NA, and IDD3P  
Measurement-Loop Pattern<sup>1</sup>**

CK_t, CK_c	CKE	Sub-Loop	Cycle Number	Command	CS_n	ACT_n	RAS_n	CAS_n/A15	WE_n/A14	ODT	C[2:0] <sup>3</sup>	BG[1:0] <sup>2</sup>	BA[1:0]	A12/BC_n	A[13,11]	A[10]/AP	A[9:7]	A[6:3]	A[2:0]	Data <sup>4</sup>			
toggling	Static High	0	0	D, D	1	0	0	0	0	0	0	0	0	0	0	0	0	0	0	0	0		
			1	D, D	1	0	0	0	0	0	0	0	0	0	0	0	0	0	0	0	0	0	0
			2	D#, D#	1	1	1	1	1	1	0	0	3 <sup>2</sup>	3	0	0	0	7	F	0	0	0	
			3	D#, D#	1	1	1	1	1	1	0	0	3 <sup>2</sup>	3	0	0	0	7	F	0	0	0	
		1	4-7	repeat Sub-Loop 0, use BG[1:0] <sup>2</sup> = 1, BA[1:0] = 1 instead																			
		2	8-11	repeat Sub-Loop 0, use BG[1:0] <sup>2</sup> = 0, BA[1:0] = 2 instead																			
		3	12-15	repeat Sub-Loop 0, use BG[1:0] <sup>2</sup> = 1, BA[1:0] = 3 instead																			
		4	16-19	repeat Sub-Loop 0, use BG[1:0] <sup>2</sup> = 0, BA[1:0] = 1 instead																			
		5	20-23	repeat Sub-Loop 0, use BG[1:0] <sup>2</sup> = 1, BA[1:0] = 2 instead																			
		6	24-27	repeat Sub-Loop 0, use BG[1:0] <sup>2</sup> = 0, BA[1:0] = 3 instead																			
		7	28-31	repeat Sub-Loop 0, use BG[1:0] <sup>2</sup> = 1, BA[1:0] = 0 instead																			
		8	32-35	repeat Sub-Loop 0, use BG[1:0] <sup>2</sup> = 2, BA[1:0] = 0 instead																			
		9	36-39	repeat Sub-Loop 0, use BG[1:0] <sup>2</sup> = 3, BA[1:0] = 1 instead																			
		10	40-43	repeat Sub-Loop 0, use BG[1:0] <sup>2</sup> = 2, BA[1:0] = 2 instead																			
		11	44-47	repeat Sub-Loop 0, use BG[1:0] <sup>2</sup> = 3, BA[1:0] = 3 instead																			
		12	48-51	repeat Sub-Loop 0, use BG[1:0] <sup>2</sup> = 2, BA[1:0] = 1 instead																			
13	52-55	repeat Sub-Loop 0, use BG[1:0] <sup>2</sup> = 3, BA[1:0] = 2 instead																					
14	56-59	repeat Sub-Loop 0, use BG[1:0] <sup>2</sup> = 2, BA[1:0] = 3 instead																					
15	60-63	repeat Sub-Loop 0, use BG[1:0] <sup>2</sup> = 3, BA[1:0] = 0 instead																					

**NOTE :**

1. DQS\_t, DQS\_c are VDDQ.
2. BG1 is don't care for x16 device
3. C[2:0] are used only for 3DS device
4. DQ signals are VDDQ.

**Table 11: IDD2NT and IDDQ2NT Measurement-Loop Pattern<sup>1</sup>**

CK_t, CK_c	CKE	Sub-Loop	Cycle Number	Command	CS_n	ACT_n	RAS_n	CAS_n/A15	WE_n/A14	ODT	C[2:0] <sup>3</sup>	BG[1:0] <sup>2</sup>	BA[1:0]	A12/BC_n	A[13,11]	A[10]/AP	A[9:7]	A[6:3]	A[2:0]	Data <sup>4</sup>			
toggling	Static High	0	0	D, D	1	0	0	0	0	0	0	0	0	0	0	0	0	0	0	0	-		
			1	D, D	1	0	0	0	0	0	0	0	0	0	0	0	0	0	0	0	0	-	
			2	D#, D#	1	1	1	1	1	1	0	0	3 <sup>2</sup>	3	0	0	0	7	F	0	0	-	
			3	D#, D#	1	1	1	1	1	1	0	0	3 <sup>2</sup>	3	0	0	0	7	F	0	0	-	
		1	4-7	repeat Sub-Loop 0, but ODT = 1 and BG[1:0] <sup>2</sup> = 1, BA[1:0] = 1 instead																			
		2	8-11	repeat Sub-Loop 0, but ODT = 0 and BG[1:0] <sup>2</sup> = 0, BA[1:0] = 2 instead																			
		3	12-15	repeat Sub-Loop 0, but ODT = 1 and BG[1:0] <sup>2</sup> = 1, BA[1:0] = 3 instead																			
		4	16-19	repeat Sub-Loop 0, but ODT = 0 and BG[1:0] <sup>2</sup> = 0, BA[1:0] = 1 instead																			
		5	20-23	repeat Sub-Loop 0, but ODT = 1 and BG[1:0] <sup>2</sup> = 1, BA[1:0] = 2 instead																			
		6	24-27	repeat Sub-Loop 0, but ODT = 0 and BG[1:0] <sup>2</sup> = 0, BA[1:0] = 3 instead																			
		7	28-31	repeat Sub-Loop 0, but ODT = 1 and BG[1:0] <sup>2</sup> = 1, BA[1:0] = 0 instead																			
		8	32-35	repeat Sub-Loop 0, but ODT = 0 and BG[1:0] <sup>2</sup> = 2, BA[1:0] = 0 instead																			For x4 and x8 only
		9	36-39	repeat Sub-Loop 0, but ODT = 1 and BG[1:0] <sup>2</sup> = 3, BA[1:0] = 1 instead																			
		10	40-43	repeat Sub-Loop 0, but ODT = 0 and BG[1:0] <sup>2</sup> = 2, BA[1:0] = 2 instead																			
		11	44-47	repeat Sub-Loop 0, but ODT = 1 and BG[1:0] <sup>2</sup> = 3, BA[1:0] = 3 instead																			
		12	48-51	repeat Sub-Loop 0, but ODT = 0 and BG[1:0] <sup>2</sup> = 2, BA[1:0] = 1 instead																			
13	52-55	repeat Sub-Loop 0, but ODT = 1 and BG[1:0] <sup>2</sup> = 3, BA[1:0] = 2 instead																					
14	56-59	repeat Sub-Loop 0, but ODT = 0 and BG[1:0] <sup>2</sup> = 2, BA[1:0] = 3 instead																					
15	60-63	repeat Sub-Loop 0, but ODT = 1 and BG[1:0] <sup>2</sup> = 3, BA[1:0] = 0 instead																					

**NOTE :**

1. DQS\_t, DQS\_c are VDDQ.
2. BG1 is don't care for x16 device
3. C[2:0] are used only for 3DS device
4. DQ signals are VDDQ.

**Table 12: IDD4R, IDD4RA, IDD4RB and IDDQ4R Measurement-Loop Pattern<sup>1</sup>**

CK_t, CK_c	CKE	Sub-Loop	Cycle Number	Command	CS_n	ACT_n	RAS_n	CAS_n/A15	WE_n/A14	ODT	C[2:0] <sup>3</sup>	BG[1:0] <sup>2</sup>	BA[1:0]	A12/BC_n	A[13,11]	A[10]/AP	A[9:7]	A[6:3]	A[2:0]	Data <sup>4</sup>		
toggling	Static High	0	0	RD	0	1	1	0	1	0	0	0	0	0	0	0	0	0	0	0	D0=00, D1=FF D2=FF, D3=00 D4=FF, D5=00 D6=00, D7=FF	
			1	D	1	0	0	0	0	0	0	0	0	0	0	0	0	0	0	0	0	-
			2,3	D#, D#	1	1	1	1	1	1	0	0	3 <sup>2</sup>	3	0	0	0	0	7	F	0	-
		1	4	RD	0	1	1	0	1	0	0	0	1	1	0	0	0	7	F	0	0	D0=FF, D1=00 D2=00, D3=FF D4=00, D5=FF D6=FF, D7=00
			5	D	1	0	0	0	0	0	0	0	0	0	0	0	0	0	0	0	0	-
			6,7	D#, D#	1	1	1	1	1	1	0	0	3 <sup>2</sup>	3	0	0	0	7	F	0	-	
		2	8-11	repeat Sub-Loop 0, use BG[1:0] <sup>2</sup> = 0, BA[1:0] = 2 instead																		
		3	12-15	repeat Sub-Loop 1, use BG[1:0] <sup>2</sup> = 1, BA[1:0] = 3 instead																		
		4	16-19	repeat Sub-Loop 0, use BG[1:0] <sup>2</sup> = 0, BA[1:0] = 1 instead																		
		5	20-23	repeat Sub-Loop 1, use BG[1:0] <sup>2</sup> = 1, BA[1:0] = 2 instead																		
		6	24-27	repeat Sub-Loop 0, use BG[1:0] <sup>2</sup> = 0, BA[1:0] = 3 instead																		
		7	28-31	repeat Sub-Loop 1, use BG[1:0] <sup>2</sup> = 1, BA[1:0] = 0 instead																		
		8	32-35	repeat Sub-Loop 0, use BG[1:0] <sup>2</sup> = 2, BA[1:0] = 0 instead																		
		9	36-39	repeat Sub-Loop 1, use BG[1:0] <sup>2</sup> = 3, BA[1:0] = 1 instead																		
		10	40-43	repeat Sub-Loop 0, use BG[1:0] <sup>2</sup> = 2, BA[1:0] = 2 instead																		
11	44-47	repeat Sub-Loop 1, use BG[1:0] <sup>2</sup> = 3, BA[1:0] = 3 instead																				
12	48-51	repeat Sub-Loop 0, use BG[1:0] <sup>2</sup> = 2, BA[1:0] = 1 instead																				
13	52-55	repeat Sub-Loop 1, use BG[1:0] <sup>2</sup> = 3, BA[1:0] = 2 instead																				
14	56-59	repeat Sub-Loop 0, use BG[1:0] <sup>2</sup> = 2, BA[1:0] = 3 instead																				
15	60-63	repeat Sub-Loop 1, use BG[1:0] <sup>2</sup> = 3, BA[1:0] = 0 instead																				

**NOTE :**

1. DQS\_t, DQS\_c are used according to RD Commands, otherwise VDDQ.
2. BG1 is don't care for x16 device
3. C[2:0] are used only for 3DS device
4. Burst Sequence driven on each DQ signal by ReadCommand.

**Table 13 : IDD4W, IDD4WA, IDD4WB and IDD4W par Measurement-Loop Pattern<sup>1</sup>**

CK_t, CK_c	CKE	Sub-Loop	Cycle Number	Command	CS_n	ACT_n	RAS_n	CAS_n/A15	WE_n/A14	ODT	C[2:0] <sup>3</sup>	BG[1:0] <sup>2</sup>	BA[1:0]	A12/BC_n	A[13,11]	A[10]/AP	A[9:7]	A[6:3]	A[2:0]	Data <sup>4</sup>		
toggling	Static High	0	0	WR	0	1	1	0	0	1	0	0	0	0	0	0	0	0	0	0	D0=00, D1=FF D2=FF, D3=00 D4=FF, D5=00 D6=00, D7=FF	
			1	D	1	0	0	0	0	1	0	0	0	0	0	0	0	0	0	0	0	-
			2,3	D#, D#	1	1	1	1	1	1	1	0	3 <sup>2</sup>	3	0	0	0	7	F	0	0	-
		1	4	WR	0	1	1	0	0	0	1	0	1	1	0	0	0	7	F	0	0	D0=FF, D1=00 D2=00, D3=FF D4=00, D5=FF D6=FF, D7=00
			5	D	1	0	0	0	0	0	1	0	0	0	0	0	0	0	0	0	0	-
			6,7	D#, D#	1	1	1	1	1	1	1	0	3 <sup>2</sup>	3	0	0	0	7	F	0	0	-
		2	8-11	repeat Sub-Loop 0, use BG[1:0] <sup>2</sup> = 0, BA[1:0] = 2 instead																		
		3	12-15	repeat Sub-Loop 1, use BG[1:0] <sup>2</sup> = 1, BA[1:0] = 3 instead																		
		4	16-19	repeat Sub-Loop 0, use BG[1:0] <sup>2</sup> = 0, BA[1:0] = 1 instead																		
		5	20-23	repeat Sub-Loop 1, use BG[1:0] <sup>2</sup> = 1, BA[1:0] = 2 instead																		
		6	24-27	repeat Sub-Loop 0, use BG[1:0] <sup>2</sup> = 0, BA[1:0] = 3 instead																		
		7	28-31	repeat Sub-Loop 1, use BG[1:0] <sup>2</sup> = 1, BA[1:0] = 0 instead																		
		8	32-35	repeat Sub-Loop 0, use BG[1:0] <sup>2</sup> = 2, BA[1:0] = 0 instead																		
		9	36-39	repeat Sub-Loop 1, use BG[1:0] <sup>2</sup> = 3, BA[1:0] = 1 instead																		
		10	40-43	repeat Sub-Loop 0, use BG[1:0] <sup>2</sup> = 2, BA[1:0] = 2 instead																		
11	44-47	repeat Sub-Loop 1, use BG[1:0] <sup>2</sup> = 3, BA[1:0] = 3 instead																				
12	48-51	repeat Sub-Loop 0, use BG[1:0] <sup>2</sup> = 2, BA[1:0] = 1 instead																				
13	52-55	repeat Sub-Loop 1, use BG[1:0] <sup>2</sup> = 3, BA[1:0] = 2 instead																				
14	56-59	repeat Sub-Loop 0, use BG[1:0] <sup>2</sup> = 2, BA[1:0] = 3 instead																				
15	60-63	repeat Sub-Loop 1, use BG[1:0] <sup>2</sup> = 3, BA[1:0] = 0 instead																				
																				For x4 and x8 only		

NOTE :

1. DQS\_t, DQS\_c are used according to WR Commands, otherwise VDDQ.
2. BG1 is don't care for x16 device
3. C[2:0] are used only for 3DS device
4. Burst Sequence driven on each DQ signal by WriteCommand.

**Table 14: IDD4WC Measurement-Loop Pattern<sup>1</sup>**

CK_t, CK_c	CKE	Sub-Loop	Cycle Number	Command	CS_n	ACT_n	RAS_n	CAS_n/A15	WE_n/A14	ODT	C[2:0] <sup>3</sup>	BG[1:0] <sup>2</sup>	BA[1:0]	A12/BC_n	A[13,11]	A[10]/AP	A[9:7]	A[6:3]	A[2:0]	Data <sup>4</sup>			
toggling	Static High	0	0	WR	0	1	1	0	0	1	0	0	0	0	0	0	0	0	0	0	D0=00, D1=FF D2=FF, D3=00 D4=FF, D5=00 D6=00, D7=FF D8=CRC		
			1,2	D, D	1	0	0	0	0	0	1	0	0	0	0	0	0	0	0	0	0	-	
			3,4	D#, D#	1	1	1	1	1	1	1	0	3 <sup>2</sup>	3	0	0	0	7	F	0	0	-	
		1	5	WR	0	1	1	0	0	0	0	1	0	1	1	0	0	0	7	F	0	D0=FF, D1=00 D2=00, D3=FF D4=00, D5=FF D6=FF, D7=00 D8=CRC	
			6,7	D, D	1	0	0	0	0	0	1	0	0	0	0	0	0	0	0	0	0	0	-
			8,9	D#, D#	1	1	1	1	1	1	1	0	3 <sup>2</sup>	3	0	0	0	7	F	0	0	-	
		2	10-14	repeat Sub-Loop 0, use BG[1:0] <sup>2</sup> = 0, BA[1:0] = 2 instead																			
		3	15-19	repeat Sub-Loop 1, use BG[1:0] <sup>2</sup> = 1, BA[1:0] = 3 instead																			
		4	20-24	repeat Sub-Loop 0, use BG[1:0] <sup>2</sup> = 0, BA[1:0] = 1 instead																			
		5	25-29	repeat Sub-Loop 1, use BG[1:0] <sup>2</sup> = 1, BA[1:0] = 2 instead																			
		6	30-34	repeat Sub-Loop 0, use BG[1:0] <sup>2</sup> = 0, BA[1:0] = 3 instead																			
		7	35-39	repeat Sub-Loop 1, use BG[1:0] <sup>2</sup> = 1, BA[1:0] = 0 instead																			
		8	40-44	repeat Sub-Loop 0, use BG[1:0] <sup>2</sup> = 2, BA[1:0] = 0 instead																			
		9	45-49	repeat Sub-Loop 1, use BG[1:0] <sup>2</sup> = 3, BA[1:0] = 1 instead																			
		10	50-54	repeat Sub-Loop 0, use BG[1:0] <sup>2</sup> = 2, BA[1:0] = 2 instead																			
11	55-59	repeat Sub-Loop 1, use BG[1:0] <sup>2</sup> = 3, BA[1:0] = 3 instead																					
12	60-64	repeat Sub-Loop 0, use BG[1:0] <sup>2</sup> = 2, BA[1:0] = 1 instead																					
13	65-69	repeat Sub-Loop 1, use BG[1:0] <sup>2</sup> = 3, BA[1:0] = 2 instead																					
14	70-74	repeat Sub-Loop 0, use BG[1:0] <sup>2</sup> = 2, BA[1:0] = 3 instead																					
15	75-79	repeat Sub-Loop 1, use BG[1:0] <sup>2</sup> = 3, BA[1:0] = 0 instead																					
																				For x4 and x8 only			

- NOTE :
1. DQS\_t, DQS\_c are used according to WR Commands, otherwise VDDQ.
  2. BG1 is don't care for x16 device
  3. C[2:0] are used only for 3DS device
  4. Burst Sequence driven on each DQ signal by Write Command.

**Table 15 : IDD5B Measurement-Loop Pattern<sup>1</sup>**

CK_t, CK_c	CKE	Sub-Loop	Cycle Number	Command	CS_n	ACT_n	RAS_n	CAS_n/A15	WE_n/A14	ODT	C[2:0] <sup>3</sup>	BG[1:0] <sup>2</sup>	BA[1:0]	A12/BC_n	A[13,11]	A[10]/AP	A[9:7]	A[6:3]	A[2:0]	Data <sup>4</sup>		
toggling	Static High	0	0	REF	0	1	0	0	1	0	0	0	0	0	0	0	0	0	0	0	-	
		1	1	D	1	0	0	0	1	0	0	0	0	0	0	0	0	0	0	0	0	-
		2	1	D	1	0	0	0	1	0	0	0	0	0	0	0	0	0	0	0	0	-
		3	1	D#, D#	1	1	1	1	1	1	0	0	3 <sup>2</sup>	3	0	0	0	7	F	0	0	-
		4	1	D#, D#	1	1	1	1	1	1	0	0	3 <sup>2</sup>	3	0	0	0	7	F	0	0	-
		5-8	repeat pattern 1...4, use BG[1:0] <sup>2</sup> = 1, BA[1:0] = 1 instead																			
		9-12	repeat pattern 1...4, use BG[1:0] <sup>2</sup> = 0, BA[1:0] = 2 instead																			
		13-16	repeat pattern 1...4, use BG[1:0] <sup>2</sup> = 1, BA[1:0] = 3 instead																			
		17-20	repeat pattern 1...4, use BG[1:0] <sup>2</sup> = 0, BA[1:0] = 1 instead																			
		21-24	repeat pattern 1...4, use BG[1:0] <sup>2</sup> = 1, BA[1:0] = 2 instead																			
		25-28	repeat pattern 1...4, use BG[1:0] <sup>2</sup> = 0, BA[1:0] = 3 instead																			
		29-32	repeat pattern 1...4, use BG[1:0] <sup>2</sup> = 1, BA[1:0] = 0 instead																			
		33-36	repeat pattern 1...4, use BG[1:0] <sup>2</sup> = 2, BA[1:0] = 0 instead																			
		37-40	repeat pattern 1...4, use BG[1:0] <sup>2</sup> = 3, BA[1:0] = 1 instead																			
		41-44	repeat pattern 1...4, use BG[1:0] <sup>2</sup> = 2, BA[1:0] = 2 instead																			
		45-48	repeat pattern 1...4, use BG[1:0] <sup>2</sup> = 3, BA[1:0] = 3 instead																			
		49-52	repeat pattern 1...4, use BG[1:0] <sup>2</sup> = 2, BA[1:0] = 1 instead																			
		53-56	repeat pattern 1...4, use BG[1:0] <sup>2</sup> = 3, BA[1:0] = 2 instead																			
		57-60	repeat pattern 1...4, use BG[1:0] <sup>2</sup> = 2, BA[1:0] = 3 instead																			
		61-64	repeat pattern 1...4, use BG[1:0] <sup>2</sup> = 3, BA[1:0] = 0 instead																			
		2	65 ... nRFC - 1	repeat Sub-Loop 1, Truncate, if necessary																		

**NOTE :**

1. DQS\_t, DQS\_c are VDDQ.
2. BG1 is don't care for x16 device.
3. C[2:0] are used only for 3DS device.
4. DQ signals are VDDQ.

For x4 and x8 only

Table 16: IDD7 Measurement-Loop Pattern<sup>1</sup>

CK <sub>t</sub> , CK <sub>c</sub>	CKE	Sub-Loop	Cycle Number	Command	CS <sub>n</sub>	ACT <sub>n</sub>	RAS <sub>n</sub>	CAS <sub>n</sub> /A15	WE <sub>n</sub> /A14	ODT	C[2:0] <sup>3</sup>	BG[1:0] <sup>2</sup>	BA[1:0]	A12/BC <sub>n</sub>	A[13,14]	A[10]/AP	A[9:7]	A[6:3]	A[2:0]	Data <sup>4</sup>			
toggling	Static High	0	0	ACT	0	0	0	0	0	0	0	0	0	0	0	0	0	0	0	0	-		
			1	RDA	0	1	1	0	1	0	0	0	0	0	0	0	0	1	0	0	0	D0=00, D1=FF D2=FF, D3=00 D4=FF, D5=00 D6=00, D7=FF	
			2	D	1	0	0	0	0	0	0	0	0	0	0	0	0	0	0	0	0	-	
			3	D#	1	1	1	1	1	1	0	0	3 <sup>2</sup>	3	0	0	0	0	7	F	0	-	
			...	repeat pattern 2...3 until nRRD - 1, if nRRD > 4. Truncate if necessary																			
		1	nRRD	ACT	0	0	0	0	0	0	0	0	0	1	1	0	0	0	0	0	0	0	-
			nRRD + 1	RDA	0	1	1	0	1	0	0	0	1	1	0	0	1	0	0	0	0	0	D0=FF, D1=00 D2=00, D3=FF D4=00, D5=FF D6=FF, D7=00
			...	repeat pattern 2 ... 3 until 2*nRRD - 1, if nRRD > 4. Truncate if necessary																			
		2	2*nRRD	repeat Sub-Loop 0, use BG[1:0] <sup>2</sup> = 0, BA[1:0] = 2 instead																			
		3	3*nRRD	repeat Sub-Loop 1, use BG[1:0] <sup>2</sup> = 1, BA[1:0] = 3 instead																			
		4	4*nRRD	repeat pattern 2 ... 3 until nFAW - 1, if nFAW > 4* nRRD. Truncate if necessary																			
		5	nFAW	repeat Sub-Loop 0, use BG[1:0] <sup>2</sup> = 0, BA[1:0] = 1 instead																			
		6	nFAW + nRRD	repeat Sub-Loop 1, use BG[1:0] <sup>2</sup> = 1, BA[1:0] = 2 instead																			
		7	nFAW + 2*nRRD	repeat Sub-Loop 0, use BG[1:0] <sup>2</sup> = 0, BA[1:0] = 3 instead																			
		8	nFAW + 3*nRRD	repeat Sub-Loop 1, use BG[1:0] <sup>2</sup> = 1, BA[1:0] = 0 instead																			
		9	nFAW + 4*nRRD	repeat Sub-Loop 4																			
		10	2*nFAW	repeat Sub-Loop 0, use BG[1:0] <sup>2</sup> = 2, BA[1:0] = 0 instead																			
		11	2*nFAW + nRRD	repeat Sub-Loop 1, use BG[1:0] <sup>2</sup> = 3, BA[1:0] = 1 instead																			
		12	2*nFAW + 2*nRRD	repeat Sub-Loop 0, use BG[1:0] <sup>2</sup> = 2, BA[1:0] = 2 instead																			
		13	2*nFAW + 3*nRRD	repeat Sub-Loop 1, use BG[1:0] <sup>2</sup> = 3, BA[1:0] = 3 instead																			
14	2*nFAW + 4*nRRD	repeat Sub-Loop 4																					
15	3*nFAW	repeat Sub-Loop 0, use BG[1:0] <sup>2</sup> = 2, BA[1:0] = 1 instead																					
16	3*nFAW + nRRD	repeat Sub-Loop 1, use BG[1:0] <sup>2</sup> = 3, BA[1:0] = 2 instead																					
17	3*nFAW + 2*nRRD	repeat Sub-Loop 0, use BG[1:0] <sup>2</sup> = 2, BA[1:0] = 3 instead																					
18	3*nFAW + 3*nRRD	repeat Sub-Loop 1, use BG[1:0] <sup>2</sup> = 3, BA[1:0] = 0 instead																					
19	3*nFAW + 4*nRRD	repeat Sub-Loop 4																					
20	4*nFAW	repeat pattern 2 ... 3 until nRC - 1, if nRC > 4*nFAW. Truncate if necessary																					

**NOTE :**

1. DQS<sub>t</sub>, DQS<sub>c</sub> are VDDQ.
2. BG1 is don't care for x16 device.
3. C[2:0] are used only for 3DS device.
4. Burst Sequence driven on each DQ signal by Read Command. Outside burst operation, DQ signals are VDDQ.

## 6. Electrical Specifications

### 6.1 IDD Specifications

IDD and IPP values are for full operating range of voltage and temperature unless otherwise noted.

**Table 17 : IDD and IDDQ Specification**

Symbol	DDR4-2400 (1.2V)	DDR4-2666 (1.2V)	DDR4-2933 (1.2V)	DDR4-3200 (1.2V)	Unit
	x16	x16	x16	x16	
$I_{DD0}$	53	93	57	104	mA
$I_{DD1}$	63	120	67	131	mA
$I_{DD2N}$	35	57	37	67	mA
$I_{DD2NT}$	40	77	44	85	mA
$I_{DD2P}$	30	42	30	30	mA
$I_{DD2Q}$	34	38	34	39	mA
$I_{DD3N}$	38	104	42	115	mA
$I_{DD3P}$	31	65	33	71	mA
$I_{DD4R}$	139	251	164	295	mA
$I_{DD4W}$	109	266	127	316	mA
$I_{DD5B}$	258	237	238	239	mA
$I_{DD7}$	179	274	210	279	mA
$I_{DD8}$	24	24	24	24	mA



**Table 18: IPP Specification**

Symbol	DDR4-2400	DDR4-2666	DDR4-2933	DDR4-3200	Unit
	x16	x16	x16	x16	
$I_{PP0}$	5	7	5	7	mA
$I_{PP3N}$	3	3	3	3	mA
$I_{PP7}$	13	32	13	32	mA

**Table 19: IDD6 Specification**

Symbol	Temperature Range	DDR4-2400	DDR4-2666	DDR4-2933	DDR4-3200	Unit	Notes
		x16	x16	x16	x16		
IDD6N	0 - 85 °C	32	32	32	32	mA	1
IDD6E	0 - 95 °C	52	52	52	52	mA	2
IDD6R	0 - 45 °C	19	19	19	19	mA	3
IDD6A	0 - 85 °C	52	52	52	52	mA	4

- Notes:
1. Applicable for MR2 settings A6 = 0 and A7 = 0.
  2. Applicable for MR2 settings A6 = 0 and A7 = 1. IDD6E is only specified for devices which support the extended temperature range feature.
  3. Applicable for MR2 settings A6 = 1 and A7 = 0. IDD6R is only specified for devices which support the reduced temperature range feature.
  4. Applicable for MR2 settings A6 = 1 and A7 = 1. IDD6A is only specified for devices which support the auto self-refresh feature.

## 6.2 Input/Output Capacitance

**Table 20: Silicon pad I/O Capacitance**

Symbol	Parameter	DDR4-1600/1866/2133		DDR4-2400/2666		DDR4-2933		DDR4-3200		Unit	NOTE
		min	max	min	max	min	max	min	max		
C <sub>IO</sub>	Input/output capacitance	0.55	1.4	0.55	1.15	0.55	1.00	0.55	1.00	pF	1,2,3
C <sub>DIO</sub>	Input/output capacitance delta	-0.1	0.1	-0.1	0.1	-0.1	0.1	-0.1	0.1	pF	1,2,3,11
C <sub>DDQS</sub>	Input/output capacitance delta DQS <sub>t</sub> and DQS <sub>c</sub>	-	0.05	-	0.05	-	0.05	-	0.05	pF	1,2,3,5
C <sub>CK</sub>	Input capacitance, CK <sub>t</sub> and CK <sub>c</sub>	0.2	0.8	0.2	0.7	0.2	0.7	0.2	0.7	pF	1,3
C <sub>DCK</sub>	Input capacitance delta CK <sub>t</sub> and CK <sub>c</sub>	-	0.05	-	0.05	-	0.05	-	0.05	pF	1,3,4
C <sub>I</sub>	Input capacitance(CTRL, ADD, CMD pins only)	0.2	0.8	0.2	0.7	0.2	0.6	0.2	0.55	pF	1,3,6
C <sub>DI_CTRL</sub>	Input capacitance delta(All CTRL pins only)	-0.1	0.1	-0.1	0.1	-0.1	0.1	-0.1	0.1	pF	1,3,7,8
C <sub>DI_ADD_CMD</sub>	Input capacitance delta(All ADD/CMD pins only)	-0.1	0.1	-0.1	0.1	-0.1	0.1	-0.1	0.1	pF	1,2,9,10
C <sub>ALERT</sub>	Input/output capacitance of ALERT	0.5	1.5	0.5	1.5	0.5	1.5	0.5	1.5	pF	1,3
C <sub>ZQ</sub>	Input/output capacitance of ZQ	-	2.3	-	2.3	-	2.3	-	2.3	pF	1,3,12
C <sub>TEN</sub>	Input capacitance of TEN	0.2	2.3	0.2	2.3	0.2	2.3	0.2	2.3	pF	1,3,13

**NOTE:**

1. This parameter is not subject to production test. It is verified by design and characterization. The silicon only capacitance is validated by de-embedding the package L & C parasitic. The capacitance is measured with VDD, VDDQ, VSS, VSSQ applied with all other signal pins floating. Measurement procedure TBD.
2. DQ, DM<sub>n</sub>, DQS<sub>T</sub>, DQS<sub>C</sub>, TDQS<sub>T</sub>, TDQS<sub>C</sub>. Although the DM, TDQS<sub>T</sub> and TDQS<sub>C</sub> pins have different functions, the loading matches DQ and DQS
3. This parameter applies to monolithic devices only; stacked/dual-die devices are not covered here
4. Absolute value CK<sub>T</sub>-CK<sub>C</sub>
5. Absolute value of C<sub>IO</sub>(DQS<sub>T</sub>)-C<sub>IO</sub>(DQS<sub>C</sub>)
6. C<sub>I</sub> applies to ODT, CS<sub>n</sub>, CKE, A0-A15, BA0-BA1, BG0-BG1, RAS<sub>n</sub>, CAS<sub>n</sub>/A15, WE<sub>n</sub>/A14, ACT<sub>n</sub> and PAR.
7. C<sub>DI\_CTRL</sub> applies to ODT, CS<sub>n</sub> and CKE
8.  $C_{DI\_CTRL} = C_I(CTRL) - 0.5 * (C_I(CLK\_T) + C_I(CLK\_C))$
9. C<sub>DI\_ADD\_CMD</sub> applies to, A0-A15, BA0-BA1, BG0-BG1, RAS<sub>n</sub>, CAS<sub>n</sub>/A15, WE<sub>n</sub>/A14, ACT<sub>n</sub> and PAR.
10.  $C_{DI\_ADD\_CMD} = C_I(ADD\_CMD) - 0.5 * (C_I(CLK\_T) + C_I(CLK\_C))$
11.  $C_{DIO} = C_{IO}(DQ, DM) - 0.5 * (C_{IO}(DQS\_T) + C_{IO}(DQS\_C))$
12. Maximum external load capacitance on ZQ pin: TBD
13. TEN pin is DRAM internally pulled low through a weak pull-down resistor to VSS.

**Table 21: DRAM package electrical specifications(x16)**

Symbol	Parameter	DDR4-1600/1866		DDR4-2133/2400/2666/2933/3200		Unit	NOTE
		min	max	min	max		
Z <sub>IO</sub>	Input/output Zpkg	45	85	45	85	Ω	1
T <sub>dIO</sub>	Input/output Pkg Delay	14	45	14	45	ps	1
L <sub>io</sub>	Input/Output Lpkg	-	3.4	-	3.4	nH	1,2
C <sub>io</sub>	Input/Output Cpkg	-	0.82	-	0.82	pF	1,3
Z <sub>IO DQS</sub>	DQS_t, DQS_c Zpkg	45	85	45	85	Ω	1
T <sub>dIO DQS</sub>	DQS_t, DQS_c Pkg Delay	14	45	14	45	ps	1
L <sub>io DQS</sub>	DQS Lpkg	-	3.4	-	3.4	nH	1,2
C <sub>io DQS</sub>	DQS Cpkg	-	0.82	-	0.82	pF	1,3
DZ <sub>DIO DQS</sub>	Delta Zpkg DQSU_t, DQSU_c	-	10	-	10	Ω	-
	Delta Zpkg DQSL_t, DQSL_c	-	10	-	10	Ω	-
D <sub>TdDIO DQS</sub>	Delta Delay DQSU_t, DQSU_c	-	5	-	5	ps	-
	Delta Delay DQSL_t, DQSL_c	-	5	-	5	ps	-
Z <sub>I CTRL</sub>	Input- CTRL pins Zpkg	50	90	50	90	Ω	1
T <sub>dI CTRL</sub>	Input- CTRL pins Pkg Delay	14	42	14	42	ps	1
L <sub>I CTRL</sub>	Input CTRL Lpkg	-	3.4	-	3.4	nH	1,2
C <sub>I CTRL</sub>	Input CTRL Cpkg	-	0.7	-	0.7	pF	1,3
Z <sub>I ADD CMD</sub>	Input- CMD ADD pins Zpkg	50	90	50	90	Ω	1
T <sub>dI ADD CMD</sub>	Input- CMD ADD pins Pkg Delay	14	52	14	52	ps	1
L <sub>I ADD CMD</sub>	Input CMD ADD Lpkg	-	3.9	-	3.9	nH	1,2
C <sub>I ADD CMD</sub>	Input CMD ADD Cpkg	-	0.86	-	0.86	pF	1,3
Z <sub>CK</sub>	CLK_t & CLK_c Zpkg	50	90	50	90	Ω	1
T <sub>dCK</sub>	CLK_t & CLK_c Pkg Delay	14	42	14	42	ps	1
L <sub>I CLK</sub>	Input CLK Lpkg	-	3.4	-	3.4	nH	1,2
C <sub>I CLK</sub>	Input CLK Cpkg	-	0.7	-	0.7	pF	1,3
DZ <sub>DCK</sub>	Delta Zpkg CLK_t & CLK_c	-	10	-	10	Ω	-
D <sub>TdCK</sub>	Delta Delay CLK_t & CLK_c	-	5	-	5	ps	-
Z <sub>OZQ</sub>	ZQ Zpkg	-	100	-	100	Ω	
T <sub>dO ZQ</sub>	ZQ Delay	20	90	20	90	ps	
Z <sub>O ALERT</sub>	ALERT Zpkg	40	100	40	100	Ω	
T <sub>dO ALERT</sub>	ALERT Delay	20	55	20	55	ps	

**NOTE :**

1. Package implementations shall meet spec if the Zpkg and Pkg Delay fall within the ranges shown, and the maximum Lpkg and Cpkg do not exceed the maximum value shown
2. It is assumed that Lpkg can be approximated as  $Lpkg = Zo \cdot Td$
3. It is assumed that Cpkg can be approximated as  $Cpkg = Td/Zo$

### 6.3 Standard Speed Bins

**Table 22: DDR4-1600 Speed Bins**

Speed Bin			DDR4-1600K		Unit	NOTE	
CL-nRCD-nRP			11-11-11				
Parameter	Symbol		min	max			
Internal read command to first data	tAA		13.75 <sup>14</sup> (13.50) <sup>5,12</sup>	18.00	ns	12	
Internal read command to first data with read DBI enabled	tAA_DBI		tAA(min) + 2nCK	tAA(max) + 2nCK	ns	12	
ACT to internal read or write delay time	tRCD		13.75 (13.50) <sup>5,12</sup>	-	ns	12	
PRE command period	tRP		13.75 (13.50) <sup>5,12</sup>	-	ns	12	
ACT to PRE command period	tRAS		35	9 x tREFI	ns	12	
ACT to ACT or REF command period	tRC		48.75 (48.50) <sup>5,12</sup>	-	ns	12	
	Normal	Read DBI					
CWL =9	CL = 9	CL = 11 (Optional) <sup>5</sup>	tCK(AVG)	1.5	1.6	ns	1,2,3,4,11,14
	CL = 10	CL = 12	tCK(AVG)	Reserved		ns	1,2,3,4,11
CWL = 9,11	CL = 10	CL = 12	tCK(AVG)	Reserved		ns	1,2,3,4
	CL = 11	CL = 13	tCK(AVG)	1.25	<1.5	ns	1,2,3,4
	CL = 12	CL = 14	tCK(AVG)	1.25	<1.5	ns	1,2,3
Supported CL Settings			(9),11,12		nCK	13,14	
Supported CL Settings with read DBI			(11),13,14		nCK	13	
Supported CWL Settings			9,11		nCK		

**Table 23: DDR4-1866 Speed Bins**

Speed Bin			DDR4-1866M		Unit	NOTE	
CL-nRCD-nRP			13-13-13				
Parameter	Symbol		min	max			
Internal read command to first data	tAA		13.92 <sup>14</sup> (13.50) <sup>5,12</sup>	18.00	ns	12	
Internal read command to first data with read DBI enabled	tAA_DBI		tAA(min) + 2nCK	tAA(max) + 2nCK	ns	12	
ACT to internal read or write delay time	tRCD		13.92 (13.50) <sup>5,12</sup>	-	ns	12	
PRE command period	tRP		13.92 (13.50) <sup>5,12</sup>	-	ns	12	
ACT to PRE command period	tRAS		34	9 x tREFI	ns	12	
ACT to ACT or REF command period	tRC		47.92 (47.50) <sup>5,12</sup>	-	ns	12	
	Normal	Read DBI					
CWL =9	CL = 9	CL = 11 (Optional) <sup>5</sup>	tCK(AVG)	1.5	1.6	ns	1,2,3,4,11,14
	CL = 10	CL = 12	tCK(AVG)	Reserved		ns	1,2,3,4,11
CWL = 9,11	CL = 10	CL = 12	tCK(AVG)	Reserved		ns	4
	CL = 11	CL = 13	tCK(AVG)	1.25	<1.5	ns	1,2,3,4,6
	CL = 12	CL = 14	tCK(AVG)	1.25	<1.5	ns	1,2,3,6
CWL = 10,12	CL = 12	CL = 14	tCK(AVG)	Reserved		ns	1,2,3,4
	CL = 13	CL = 15	tCK(AVG)	1.071	<1.25	ns	1,2,3,4
	CL = 14	CL = 16	tCK(AVG)	1.071	<1.25	ns	1,2,3
Supported CL Settings			9,11,12,13,14		nCK	13,14	
Supported CL Settings with read DBI			11,13,14,15,16		nCK	13	
Supported CWL Settings			9,10,11,12		nCK		

**Table 24: DDR4-2133 Speed Bins**

Speed Bin			DDR4-2133P		Unit	NOTE	
CL-nRCD-nRP			15-15-15				
Parameter	Symbol		min	max			
Internal read command to first data	tAA		14.06 <sup>14</sup> (13.50) <sup>5,12</sup>	18.00	ns	12	
Internal read command to first data with read DBI enabled	tAA_DBI		tAA(min) + 3nCK	tAA(max) + 3nCK	ns	12	
ACT to internal read or write delay time	tRCD		14.06 (13.50) <sup>5,12</sup>	-	ns	12	
PRE command period	tRP		14.06 (13.50) <sup>5,12</sup>	-	ns	12	
ACT to PRE command period	tRAS		33	9 x tREFI	ns	12	
ACT to ACT or REF command period	tRC		47.06 (46.50) <sup>5,12</sup>	-	ns	12	
	Normal	Read DBI					
CWL = 9	CL = 9	CL = 11 (Optional) <sup>5</sup>	tCK(AVG)	1.5	1.6	ns	1,2,3,4,11,14
	CL = 10	CL = 12	tCK(AVG)	Reserved		ns	1,2,3,11
CWL = 9,11	CL = 11	CL = 13	tCK(AVG)	1.25	<1.5	ns	1,2,3,4,7
	CL = 12	CL = 14	tCK(AVG)	1.25	<1.5	ns	1,2,3,7
CWL = 10,12	CL = 13	CL = 15	tCK(AVG)	1.071	<1.25	ns	1,2,3,4,7
	CL = 14	CL = 16	tCK(AVG)	1.071	<1.25	ns	1,2,3,7
CWL = 11,14	CL = 14	CL = 17	tCK(AVG)	Reserved		ns	1,2,3,4
	CL = 15	CL = 18	tCK(AVG)	0.938	<1.071	ns	1,2,3,4
	CL = 16	CL = 19	tCK(AVG)	0.938	<1.071	ns	1,2,3
Supported CL Settings			(9),(11),12,(13),14,15,16		nCK	13,14	
Supported CL Settings with read DBI			(11),(13),14,(15),16,18,19		nCK		
Supported CWL Settings			9,10,11,12,14		nCK		

**Table 25: DDR4-2400 Speed Bins**

Speed Bin			DDR4-2400T		Unit	NOTE	
CL-nRCD-nRP			17-17-17				
Parameter	Symbol		min	max			
Internal read command to first data	tAA		14.16 <sup>14</sup> (13.75) <sup>5,12</sup>	18.00	ns	12	
Internal read command to first data with read DBI enabled	tAA_DBI		tAA(min) +3nCK	tAA(max) +3nCK	ns	12	
ACT to internal read or write delay time	tRCD		14.16 (13.75) <sup>5,12</sup>	-	ns	12	
PRE command period	tRP		14.16 (13.75) <sup>5,12</sup>	-	ns	12	
ACT to PRE command period	tRAS		32	9 x tREFI	ns	12	
ACT to ACT or REF Command period	tRC		46.16 (45.75) <sup>5,12</sup>	-	ns	12	
	Normal	Read DBI					
CWL = 9	CL = 9	CL = 11 (Optional) <sup>5</sup>	tCK(AVG)	Reserved		ns	1,2,3,4,11
	CL = 10	CL = 12	tCK(AVG)	1.5	1.6	ns	1,2,3,4,11
CWL = 9,11	CL = 10	CL = 12	tCK(AVG)	Reserved		ns	4
	CL = 11	CL = 13	tCK(AVG)	1.25	<1.5	ns	1,2,3,4,8
	CL = 12	CL = 14	tCK(AVG)	1.25	<1.5	ns	1,2,3,8
CWL = 10,12	CL = 12	CL = 14	tCK(AVG)	Reserved		ns	4
	CL = 13	CL = 15	tCK(AVG)	1.071	<1.25	ns	1,2,3,4,8
	CL = 14	CL = 16	tCK(AVG)	1.071	<1.25	ns	1,2,3,8
CWL = 11,14	CL = 14	CL = 17	tCK(AVG)	Reserved		ns	4
	CL = 15	CL = 18	tCK(AVG)	0.938	<1.071	ns	1,2,3,4,8
	CL = 16	CL = 19	tCK(AVG)	0.938	<1.071	ns	1,2,3,8
CWL = 12,16	CL = 15	CL = 18	tCK(AVG)	Reserved		ns	1,2,3,4
	CL = 16	CL = 19	tCK(AVG)	Reserved		ns	1,2,3,4
	CL = 17	CL = 20	tCK(AVG)	0.833	<0.938	ns	
	CL = 18	CL = 21	tCK(AVG)	0.833	<0.938	ns	1,2,3
Supported CL Settings			10,11,12,13,14,15,16,17,18		nCK	13	
Supported CL Settings with read DBI			12,13,14,15,16,18,19,20,21		nCK		
Supported CWL Settings			9,10,11,12,14,16		nCK		

**Table 26 : DDR4-2666 Speed Bins**

Speed Bin			DDR4-2666V		Unit	NOTE	
CL-nRCD-nRP			19-19-19				
Parameter	Symbol		min	max			
Internal read command to first data	tAA		14.25 <sup>14</sup> (13.75) <sup>5,12</sup>	18.00	ns	12	
Internal read command to first data with read DBI enabled	tAA_DBI		tAA(min) + 3nCK	tAA(max) +3nCK	ns	12	
ACT to internal read or write delay time	tRCD		14.25 (13.75) <sup>5,12</sup>	-	ns	12	
PRE command period	tRP		14.25 (13.75) <sup>5,12</sup>	-	ns	12	
ACT to PRE command period	tRAS		32	9 x tREFI	ns	12	
ACT to ACT or REF command period	tRC		46.25 (45.75) <sup>5,12</sup>	-	ns	12	
	Normal	Read DBI					
CWL =9	CL = 9	CL = 11	tCK(AVG)	Reserved		ns	1,2,3,4,11
	CL = 10	CL = 12	tCK(AVG)	1.5	1.6	ns	1,2,3,11
CWL = 9,11	CL = 10	CL = 12	tCK(AVG)	Reserved		ns	4
	CL = 11	CL = 13	tCK(AVG)	1.25	<1.5	ns	1,2,3,4,9
	CL = 12	CL = 14	tCK(AVG)	1.25	<1.5	ns	1,2,3,9
CWL = 10,12	CL = 12	CL = 14	tCK(AVG)	Reserved		ns	4
	CL = 13	CL = 15	tCK(AVG)	1.071	<1.25	ns	1,2,3,4,9
	CL = 14	CL = 16	tCK(AVG)	1.071	<1.25	ns	1,2,3,9
CWL = 11,14	CL = 14	CL = 17	tCK(AVG)	Reserved		ns	4
	CL = 15	CL = 18	tCK(AVG)	0.937	<1.071	ns	1,2,3,4,9
	CL = 16	CL = 19	tCK(AVG)	0.937	<1.071	ns	1,2,3,9
CWL = 12,16	CL = 15	CL = 18	tCK(AVG)	Reserved		ns	4
	CL = 16	CL = 19	tCK(AVG)	Reserved		ns	1,2,3,4,9
	CL = 17	CL = 20	tCK(AVG)	0.833	<0.937	ns	1,2,3,4,9
	CL = 18	CL = 21	tCK(AVG)	0.833	<0.937	ns	1,2,3
CWL = 14,18	CL = 17	CL = 20	tCK(AVG)	Reserved		ns	1,2,3,4
	CL = 18	CL = 21	tCK(AVG)	Reserved		ns	1,2,3,4
	CL = 19	CL = 22	tCK(AVG)	0.75	<0.833	ns	1,2,3,4
	CL = 20	CL = 23	tCK(AVG)	0.75	<0.833	ns	1,2,3
Supported CL Settings			10,(11),12,(13),14,(15),16,(17),18,19,20		nCK	13	
Supported CL Settings with read DBI			12,(13),14,(15),16,(18),19,(20),21,22,23		nCK		
Supported CWL Settings			9,10,11,12,14,16,18		nCK		



**Table 27: DDR4-2933 Speed Bins**

Speed Bin			DDR4-2933Y		Unit	NOTE	
CL-nRCD-nRP			21-21-21				
Parameter	Symbol		min	max			
Internal read command to first data	tAA		14.32 <sup>14</sup> (13.75) <sup>5,12</sup>	18.00	ns	12	
Internal read command to first data with read DBI enabled	tAA_DBI		tAA(min) + 4nCK	tAA(max) + 4nCK	ns	12	
ACT to internal read or write delay time	tRCD		14.32 (13.75) <sup>5,12</sup>	-	ns	12	
PRE command period	tRP		14.32 (13.75) <sup>5,12</sup>	-	ns	12	
ACT to PRE command period	tRAS		32	9 x tREFI	ns	12	
ACT to ACT or REF command period	tRC		46.32 (45.75) <sup>5,12</sup>	-	ns	12	
	Normal	ReadDBI					
CWL = 9	CL = 9	CL = 11	tCK(AVG)	Reserved		ns	1,2,3,4,11
	CL = 10	CL = 12	tCK(AVG)	1.5	1.6	ns	1,2,3,11
CWL = 9,11	CL = 10	CL = 12	tCK(AVG)	Reserved		ns	1,2,3,4
	CL = 11	CL = 13	tCK(AVG)	1.25	<1.5	ns	1,2,3,4,13
	CL = 12	CL = 14	tCK(AVG)	1.25	<1.5	ns	1,2,3,15
CWL = 10,12	CL = 12	CL = 14	tCK(AVG)	Reserved		ns	1,2,3,4
	CL = 13	CL = 15	tCK(AVG)	1.071	<1.25	ns	1,2,3,4,15
	CL = 14	CL = 16	tCK(AVG)	1.071	<1.25	ns	1,2,3,15
CWL = 11,14	CL = 14	CL = 17	tCK(AVG)	Reserved		ns	1,2,3,4
	CL = 15	CL = 18	tCK(AVG)	0.937	<1.071	ns	1,2,3,4,15
	CL = 16	CL = 19	tCK(AVG)	0.937	<1.071	ns	1,2,3,15
CWL = 12,16	CL = 15	CL = 18	tCK(AVG)	Reserved		ns	1,2,3,4
	CL = 16	CL = 19	tCK(AVG)	Reserved		ns	1,2,3,4,15
	CL = 17	CL = 20	tCK(AVG)	0.833	0.937	ns	1,2,3,4,15
	CL = 18	CL = 21	tCK(AVG)	0.833	0.937	ns	1,2,3,15
	CL = 17	CL = 20	tCK(AVG)	Reserved		ns	1,2,3,4
CWL = 14,18	CL = 18	CL = 21	tCK(AVG)	Reserved		ns	1,2,3,4,15
	CL = 19	CL = 22	tCK(AVG)	0.75	<0.833	ns	1,2,3,4,15
	CL = 20	CL = 23	tCK(AVG)	0.75	<0.833	ns	1,2,3,15
	CL = 19	CL = 23	tCK(AVG)	Reserved		ns	1,2,3,4
CWL = 16,20	CL = 20	CL = 24	tCK(AVG)	Reserved		ns	1,2,3,4
	CL = 21	CL = 26	tCK(AVG)	0.682	<0.75	ns	1,2,3,4
	CL = 22	CL = 26	tCK(AVG)	0.682	<0.75	ns	1,2,3
	Supported CL Settings			10,(11),12,(13),14,(15),16,(17),18,(19),20,21,22		nCK	13
Supported CL Settings with read DBI			12,(13),14,(15),16,(18),19,(20),21,(22),23,25,26		nCK	13	
Supported CWL Settings			9,10,11,12,14,15,16,18,20		nCK		

**Table 28 : DDR4-3200 Speed Bins**

Speed Bin			DDR4-3200AA		Unit	NOTE	
CL-nRCD-nRP			22-22-22				
Parameter	Symbol		min	max			
Internal read command to first data	tAA		13.75	18.00	ns	12	
Internal read command to first data with read DBI enabled	tAA_DBI		tAA(min) + 4nCK	tAA(max) + 4nCK	ns	12	
ACT to internal read or write delay time	tRCD		13.75	-	ns	12	
PRE command period	tRP		13.75	-	ns	12	
ACT to PRE command period	tRAS		32	9 x tREFI	ns	12	
ACT to ACT or REF command period	tRC		45.75	-	ns	12	
	Normal	ReadDBI					
CWL = 9	CL = 9	CL = 11	tCK(AVG)	Reserved		ns	1,2,3,4,11
	CL = 10	CL = 12	tCK(AVG)	Reserved		ns	1,2,3,4,11
CWL = 9,11	CL = 10	CL = 12	tCK(AVG)	Reserved		ns	1,2,3,4
	CL = 11	CL = 13	tCK(AVG)	1.25	<1.5	ns	1,2,3,4,10
	CL = 12	CL = 14	tCK(AVG)	1.25	<1.5	ns	1,2,3,10
CWL = 10,12	CL = 12	CL = 14	tCK(AVG)	Reserved		ns	1,2,3,4
	CL = 13	CL = 15	tCK(AVG)	1.071	<1.25	ns	1,2,3,4,10
	CL = 14	CL = 16	tCK(AVG)	1.071	<1.25	ns	1,2,3,10
CWL = 11,14	CL = 14	CL = 17	tCK(AVG)	Reserved		ns	1,2,3,4
	CL = 15	CL = 18	tCK(AVG)	0.937	<1.071	ns	1,2,3,4,10
	CL = 16	CL = 19	tCK(AVG)	0.937	<1.071	ns	1,2,3,10
CWL = 12,16	CL = 15	CL = 18	tCK(AVG)	Reserved		ns	1,2,3,4
	CL = 16	CL = 19	tCK(AVG)	Reserved		ns	1,2,3,4,10
	CL = 17	CL = 20	tCK(AVG)	0.833	<0.937	ns	1,2,3,4,10
	CL = 18	CL = 21	tCK(AVG)	0.833	<0.937	ns	1,2,3,10
CWL = 14,18	CL = 17	CL = 20	tCK(AVG)	Reserved		ns	1,2,3,4
	CL = 18	CL = 21	tCK(AVG)	Reserved		ns	1,2,3,4,10
	CL = 19	CL = 22	tCK(AVG)	0.75	<0.833	ns	1,2,3,4,10
	CL = 20	CL = 23	tCK(AVG)	0.75	<0.833	ns	1,2,3,10
CWL = 16,20	CL = 20	CL = 24	tCK(AVG)	Reserved		ns	1,2,3,4
	CL = 22	CL = 26	tCK(AVG)	0.625	<0.75	ns	1,2,3,4
	CL = 24	CL = 28	tCK(AVG)	0.625	<0.75	ns	1,2,3
Supported CL Settings			10,11,12,13,14,15,16,17,18,19,20,22,24		nCK	13	
Supported CL Settings with read DBI			12,13,14,15,16,18,19,20,21,22,23,24,26, 28		nCK		
Supported CWL Settings			9,10,11,12,14,16,18,20		nCK		

## Speed Bin Table Notes

### Absolute Specification

- VDDQ = VDD = 1.20V +/- 0.06 V

- VPP = 2.5V +0.25/-0.125 V

- The values defined with above-mentioned table are DLL ON case.

- DDR4-1600, 1866, 2133, 2400 and 2666 Speed Bin Tables are valid only when Geardown Mode is disabled.

1. The CL setting and CWL setting result in tCK(avg).MIN and tCK(avg).MAX requirements. When making a selection of tCK(avg), both need to be fulfilled: Requirements from CL setting as well as requirements from CWL setting.
2. tCK(avg).MIN limits: Since CAS Latency is not purely analog - data and strobe output are synchronized by the DLL - all possible intermediate frequencies may not be guaranteed. An application should use the next smaller JEDEC standard tCK(avg) value (1.5, 1.25, 1.071, 0.938, 0.833 or 0.750 ns) when calculating CL [nCK] = tAA [ns] / tCK(avg) [ns], rounding up to the next 'Supported CL', where tAA = 12.5ns and tCK(avg) = 1.3 ns should only be used for CL = 10 calculation.
3. tCK(avg).MAX limits: Calculate tCK(avg) = tAA.MAX / CL SELECTED and round the resulting tCK(avg) down to the next valid speed bin (i.e. 1.5ns or 1.25ns or 1.071 ns or 0.938 ns or 0.833 ns or 0.750 ns). This result is tCK(avg).MAX corresponding to CL SELECTED.
4. 'Reserved' settings are not allowed. User must program a different value.
5. 'Optional' settings allow certain devices in the industry to support this setting, however, it is not a mandatory feature. Refer to supplier's data sheet and/or the DIMM SPD information if and how this setting is supported.
6. Any DDR4-1866 speed bin also supports functional operation at lower frequencies as shown in the table which are not subject to Production Tests but verified by Design/Characterization.
7. Any DDR4-2133 speed bin also supports functional operation at lower frequencies as shown in the table which are not subject to Production Tests but verified by Design/Characterization.
8. Any DDR4-2400 speed bin also supports functional operation at lower frequencies as shown in the table which are not subject to Production Tests but verified by Design/Characterization.
9. Any DDR4-2666 speed bin also supports functional operation at lower frequencies as shown in the table which are not subject to Production Tests but verified by Design/Characterization.
10. Reserved for DDR4-3200 speed bin.
11. DDR4-1600 AC timing apply if DRAM operates at lower than 1600 MT/s data rate.
12. Parameter apply from tCK(avg)min to tCH(avg)max at all standard JEDEC clock period values as stated in the Speed Bin Tables.
13. CL number in parentheses, it means that these numbers are optional.
14. DDR4 SDRAM supports CL=9 as long as a system meets tAA(min).

## 6.4 Electrical Characteristics & AC Timing

### 6.4.1 Reference Load for AC Timing and Output Slew Rate

Figure 3 represents the effective reference load of 50 ohms used in defining the relevant AC timing parameters of the device as well as output slew rate measurements.

It is not intended as a precise representation of any particular system environment or a depiction of the actual load presented by a production tester. System designers should use IBIS or other simulation tools to correlate the timing reference load to a system environment. Manufacturers correlate to their production test conditions, generally one or more coaxial transmission lines terminated at the tester electronics.

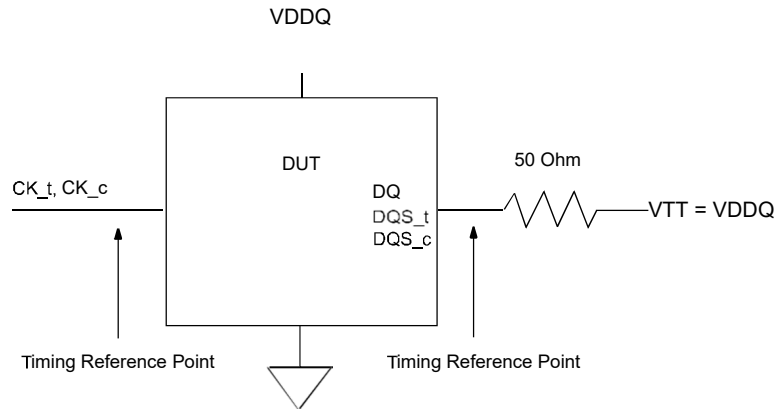

Figure 3. Reference Load for AC Timing and Output Slew Rate

### 6.4.2 tREFI

Average periodic Refresh interval (tREFI) of DDR4 SDRAM is defined as shown in the table.

Table 29: tREFI by device density

Parameter	Symbol	8Gb	Units
Average periodic refresh interval	tREFI	0°C ≤ TCASE ≤ 85°C	7.8 μs
		85°C < TCASE ≤ 95°C	3.9 μs

### 6.4.3 Timing Parameters by Speed Grade

#### Table 30: Timing Parameters by Speed Bin for DDR4-1600 to DDR4-2400

Speed		DDR4-1600		DDR4-1866		DDR4-2133		DDR4-2400		Units	NOTE	
Parameter	Symbol	MIN	MAX	MIN	MAX	MIN	MAX	MIN	MAX			
<b>Clock Timing</b>												
Minimum Clock Cycle Time (DLL off mode)	tCK (DLL_OFF)	8	20	8	20	8	20	8	20	ns		
Average Clock Period	tCK(avg)	1.25	<1.5	1.071	<1.25	0.938	<1.071	0.833	<0.938	ns	35,36	
Average high pulse width	tCH(avg)	0.48	0.52	0.48	0.52	0.48	0.52	0.48	0.52	tCK(avg)		
Average low pulse width	tCL(avg)	0.48	0.52	0.48	0.52	0.48	0.52	0.48	0.52	tCK(avg)		
Absolute Clock Period	tCK(abs)	tCK(avg)min + tJIT(per)min_tot	tCK(avg)max + tJIT(per)max_tot	tCK(avg)min + tJIT(per)min_tot	tCK(avg)max + tJIT(per)max_tot	tCK(avg)min + tJIT(per)min_tot	tCK(avg)max + tJIT(per)max_tot	tCK(avg)min + tJIT(per)min_tot	tCK(avg)max + tJIT(per)max_tot	tCK(avg)		
Absolute clock HIGH pulse width	tCH(abs)	0.45	-	0.45	-	0.45	-	0.45	-	tCK(avg)	23	
Absolute clock LOW pulse width	tCL(abs)	0.45	-	0.45	-	0.45	-	0.45	-	tCK(avg)	24	
Clock Period Jitter- total	JIT(per)_tot	-63	63	-54	54	-47	47	-42	42	ps	25	
Clock Period Jitter- deterministic	JIT(per)_dj	-31	31	-27	27	-23	23	-21	21	ps	26	
Clock Period Jitter during DLL locking period	tJIT(per, lck)	-50	50	-43	43	-38	38	-33	33	ps		
Cycle to Cycle Period Jitter	tJIT(cc)_total	125		107		94		83		ps	25	
Cycle to Cycle Period Jitterdeterministic	tJIT(cc)_dj	63		54		47		42		ps	26	
Cycle to Cycle Period Jitter during DLL locking period	tJIT(cc, lck)	100		86		75		67		ps		
Duty Cycle Jitter	tJIT(duty)	TBD	TBD	TBD	TBD	TBD	TBD	TBD	TBD	ps		
Cumulative error across 2 cycles	tERR(2per)	-92	92	-79	79	-69	69	-61	61	ps		
Cumulative error across 3 cycles	tERR(3per)	-109	109	-94	94	-82	82	-73	73	ps		
Cumulative error across 4 cycles	tERR(4per)	-121	121	-104	104	-91	91	-81	81	ps		
Cumulative error across 5 cycles	tERR(5per)	-131	131	-112	112	-98	98	-87	87	ps		
Cumulative error across 6 cycles	tERR(6per)	-139	139	-119	119	-104	104	-92	92	ps		
Cumulative error across 7 cycles	tERR(7per)	-145	145	-124	124	-109	109	-97	97	ps		
Cumulative error across 8 cycles	tERR(8per)	-151	151	-129	129	-113	113	-101	101	ps		
Cumulative error across 9 cycles	tERR(9per)	-156	156	-134	134	-117	117	-104	104	ps		
Cumulative error across 10 cycles	tERR(10per)	-160	160	-137	137	-120	120	-107	107	ps		
Cumulative error across 11 cycles	tERR(11per)	-164	164	-141	141	-123	123	-110	110	ps		
Cumulative error across 12 cycles	tERR(12per)	-168	168	-144	144	-126	126	-112	112	ps		
Cumulative error across 13 cycles	tERR(13per)	-172	172	-147	147	-129	129	-114	114	ps		
Cumulative error across 14 cycles	tERR(14per)	-175	175	-150	150	-131	131	-116	116	ps		
Cumulative error across 15 cycles	tERR(15per)	-178	178	-152	152	-133	133	-118	118	ps		
Cumulative error across 16 cycles	tERR(16per)	-180	180	-155	155	-135	135	-120	120	ps		
Cumulative error across 17 cycles	tERR(17per)	-183	183	-157	157	-137	137	-122	122	ps		
Cumulative error across 18 cycles	tERR(18per)	-185	185	-159	159	-139	139	-124	124	ps		
Cumulative error across n = 13, 14, . . . 49, 50 cycles	tERR(nper)	$tERR(nper)min = ((1 + 0.68ln(n)) * tJIT(per)_total min)$ $tERR(nper)max = ((1 + 0.68ln(n)) * tJIT(per)_total max)$									ps	
Command and Address setup time to CK_t, CK_c referenced to Vih(ac) / Vil(ac) levels	tIS(base)	115	-	100	-	80	-	62	-	ps		
Command and Address setup time to CK_t, CK_c referenced to Vref levels	tIS(Vref)	215	-	200	-	180	-	162	-	ps		
Command and Address hold timeto CK_t, CK_c referenced to Vih(dc) /Vil(dc) levels	tIH(base)	140	-	125	-	105	-	87	-	ps		
Command and Address hold time to CK_t, CK_c referenced to Vref levels	tIH(Vref)	215	-	200	-	180	-	162	-	ps		
Control and Address Input pulse width for each input	tIPW	600	-	525	-	460	-	410	-	ps		
<b>Command and Address Timing</b>												
CAS_n to CAS_n command delay for same bank group	tCCD_L	Max(5nCK, 6.250ns)	-	Max(5nCK, 5.355ns)	-	Max(5nCK, 5.355ns)	-	Max(5nCK, 5.000ns)	-	nCK	34	

Speed		DDR4-1600		DDR4-1866		DDR4-2133		DDR4-2400		Units	NOTE
Parameter	Symbol	MIN	MAX	MIN	MAX	MIN	MAX	MIN	MAX		
CAS <sub>n</sub> to CAS <sub>n</sub> command delay for different bank group	tCCD_S	4	-	4	-	4	-	4	-	nCK	34
ACTIVATE to ACTIVATE Command delay to different bank group for 2KB page size	tRRD_S(2K)	Max(4nCK, 6ns)	-	Max(4nCK, 5.3ns)	-	Max(4nCK, 5.3ns)	-	Max(4nCK, 5.3ns)	-	nCK	34
ACTIVATE to ACTIVATE Command delay to different bank group for 2KB page size	tRRD_S(1K)	Max(4nCK, 5ns)	-	Max(4nCK, 4.2ns)	-	Max(4nCK, 3.7ns)	-	Max(4nCK, 3.3ns)	-	nCK	34
ACTIVATE to ACTIVATE Command delay to different bank group for 1/2KB page size	tRRD_S(1/2K)	Max(4nCK, 5ns)	-	Max(4nCK, 4.2ns)	-	Max(4nCK, 3.7ns)	-	Max(4nCK, 3.3ns)	-	nCK	34
ACTIVATE to ACTIVATE Command delay to same bank group for 2KB page size	tRRD_L(2K)	Max(4nCK, 7.5ns)	-	Max(4nCK, 6.4ns)	-	Max(4nCK, 6.4ns)	-	Max(4nCK, 6.4ns)	-	nCK	34
ACTIVATE to ACTIVATE Command delay to same bank group for 1KB page size	tRRD_L(1K)	Max(4nCK, 6ns)	-	Max(4nCK, 5.3ns)	-	Max(4nCK, 5.3ns)	-	Max(4nCK, 4.9ns)	-	nCK	34
ACTIVATE to ACTIVATE Command delay to same bank group for 1/2KB page size	tRRD_L(1/2K)	Max(4nCK, 6ns)	-	Max(4nCK, 5.3ns)	-	Max(4nCK, 5.3ns)	-	Max(4nCK, 4.9ns)	-	nCK	34
Four activate window for 2KB page size	tFAW_2K	Max(28nCK, 35ns)	-	Max(28nCK, 30ns)	-	Max(28nCK, 30ns)	-	Max(28nCK, 30ns)	-	ns	34
Four activate window for 1KB page size	tFAW_1K	Max(20nCK, 25ns)	-	Max(20nCK, 23ns)	-	Max(20nCK, 21ns)	-	Max(20nCK, 21ns)	-	ns	34
Four activate window for 1/2KB page size	tFAW_1/2K	Max(16nCK, 20ns)	-	Max(16nCK, 17ns)	-	Max(16nCK, 15ns)	-	Max(16nCK, 13ns)	-	ns	34
Delay from start of internal write transaction to internal read command for different bank group	tWTR_S	max(2nCK, 2.5ns)	-	max(2nCK, 2.5ns)	-	max(2nCK, 2.5ns)	-	max(2nCK, 2.5ns)	-		1,2, 34
Delay from start of internal write transaction to internal read command for same bank group	tWTR_L	max(4nCK, 7.5ns)	-	max(4nCK, 7.5ns)	-	max(4nCK, 7.5ns)	-	max(4nCK, 7.5ns)	-		1,34
Internal READ Command to PRE-CHARGE Command delay	tRTP	max(4nCK, 7.5ns)	-	max(4nCK, 7.5ns)	-	max(4nCK, 7.5ns)	-	Max(4nCK, 7.5ns)	-		
WRITE recovery time	tWR	15	-	15	-	15	-	15	-	ns	1
Write recovery time when CRC and DM are enabled	tWR_CRC_DM	tWR+max(4nCK, 3.75ns)	-	tWR+max(5nCK, 3.75ns)	-	tWR+max(5nCK, 3.75ns)	-	tWR+max(5nCK, 3.75ns)	-	ns	1, 28
delay from start of internal write transaction to internal read command for different bank group with both CRC and DM enabled	tWTR_S_C RC_DM	tWTR_S+max(4nCK, 3.75ns)	-	tWTR_S+max(5nCK, 3.75ns)	-	tWTR_S+max(5nCK, 3.75ns)	-	tWTR_S+max(5nCK, 3.75ns)	-	ns	2, 29, 34
delay from start of internal write transaction to internal read command for same bank group with both CRC and DM enabled	tWTR_L_C RC_DM	tWTR_L+max(4nCK, 3.75ns)	-	tWTR_L+max(5nCK, 3.75ns)	-	tWTR_L+max(5nCK, 3.75ns)	-	tWTR_L+max(5nCK, 3.75ns)	-	ns	3,30, 34
DLL locking time	tDLLK	597	-	597	-	768	-	768	-	nCK	
Mode Register Set command cycle time	tMRD	8	-	8	-	8	-	8	-	nCK	
Mode Register Set command update delay	tMOD	max(24nCK, 15ns)	-	max(24nCK, 15ns)	-	max(24nCK, 15ns)	-	max(24nCK, 15ns)	-		
Multi-Purpose Register Recovery Time	tMPRR	1	-	1	-	1	-	1	-	nCK	33
Multi Purpose Register Write Recovery Time	tWR_MPR	tMOD (min) + AL + PL	-	tMOD (min) + AL + PL	-	tMOD (min) + AL + PL	-	tMOD (min) + AL + PL	-	-	
Auto precharge write recovery + pre-charge time	tDAL(min)	Programmed WR + roundup ( tRP / tCK(avg) )								nCK	
<b>CS<sub>n</sub> to Command Address Latency</b>											
CS <sub>n</sub> to Command Address Latency	tCAL	3	-	4	-	4	-	5	-	nCK	
<b>DRAM Data Timing</b>											
DQS <sub>t</sub> , DQS <sub>c</sub> to DQ skew, per group, per access	tDQSQ	-	0.16	-	0.16	-	0.16	-	0.17	tCK(avg) / 2	13, 18
DQ output hold time from DQS <sub>t</sub> , DQS <sub>c</sub>	tQH	0.76	-	0.76	-	0.76	-	0.74	-	tCK(avg) / 2	13, 17, 18

Speed		DDR4-1600		DDR4-1866		DDR4-2133		DDR4-2400		Units	NOTE
Parameter	Symbol	MIN	MAX	MIN	MAX	MIN	MAX	MIN	MAX		
DQS_t, DQS_c differential READ Preamble(1 clock preamble)	tRPRE	0.9	-	0.9	-	0.9	-	0.9	-	tCK	
DQS_t, DQS_c differential READ Preamble(2 clock preamble)	tRPRE2	1.8	-	1.8	-	1.8	-	1.8	-	tCK	
DQS_t, DQS_c differential READ Postamble	tRPST	0.33	-	0.33	-	0.33	-	0.33	-	tCK	
DQS_t, DQS_c differential output high time	tQSH	0.4	-	0.4	-	0.4	-	0.4	-	tCK	21
DQS_t, DQS_c differential output low time	tQSL	0.4	-	0.4	-	0.4	-	0.4	-	tCK	20
DQS_t, DQS_c differential WRITE Preamble	tWPRE	0.9	-	0.9	-	0.9	-	0.9	-	tCK	
DQS_t, DQS_c differential WRITE Preamble(2 clock preamble)	tWPRE2	NA	-	NA	-	NA	-	1.8	-	tCK	
DQS_t, DQS_c differential WRITE Postamble	tWPST	0.33	-	0.33	-	0.33	-	0.33	-	tCK	
DQS_t and DQS_c low-impedance time (Referenced from RL-1)	tLZ(DQS)	-450	225	-390	195	-360	180	-300	150	ps	
DQS_t and DQS_c high-impedance time (Referenced from RL+BL/2)	tHZ(DQS)	-	225	-	195	-	180	-	150	ps	
DQS_t, DQS_c differential input low pulse width	tDQSL	0.46	0.54	0.46	0.54	0.46	0.54	0.46	0.54	tCK	
DQS_t, DQS_c differential input high pulse width	tDQSH	0.46	0.54	0.46	0.54	0.46	0.54	0.46	0.54	tCK	
DQS_t, DQS_c rising edge to CK_t, CK_c rising edge (1 clock preamble)	tDQSS	-0.27	0.27	-0.27	0.27	-0.27	0.27	-0.27	0.27	tCK	
DQS_t, DQS_c falling edge setup time to CK_t, CK_c rising edge	tDSS	0.18	-	0.18	-	0.18	-	0.18	-	tCK	
DQS_t, DQS_c falling edge hold time from CK_t, CK_c rising edge	tDSH	0.18	-	0.18	-	0.18	-	0.18	-	tCK	
DQS_t, DQS_c rising edge output timing locatino from rising CK_t, CK_c with DLL On mode	tDQSK	-225	225	-195	195	-180	180	-175	175	ps	
<b>MPSM Timing</b>											
Command path disable delay upon MPSM entry	tMPED	MIN = tMOD(min) + tCPDED(min)								tCK	
Valid clock requirement after MPSM entry	tCKMPE	MIN = tMOD(min) + tCPDED(min)								tCK	
Valid clock requirement before MPSM exit	tCKMPX	MIN = tCKSRX(min)								tCK	
Exit MPSM to commands not requiring a locked DLL	tXMP	MIN = tXS(min)								tCK	
Exit MPSM to commands requiring a locked DLL	tXMPDLL	MIN = tXMP(min) + tXSDLL(mi)								tCK	
CS setup time to CKE	tMPX_S	MIN = tIS(min) + tIH(min)								ns	
CS_n High hold time to CKE rising edge	tMPX_HH	MIN = tXP(min)								ns	
CS_n Low hold time to CKE rising edge	tMPX_LH	12	tXMP-10ns	12	tXMP-10ns	12	tXMP-10ns	12	tXMP-10ns	ns	
<b>Calibration Timing</b>											
Power-up and RESET calibration time	tZQinit	1024	-	1024	-	1024	-	1024	-	nCK	
Normal operation Full calibration time	tZQoper	512	-	512	-	512	-	512	-	nCK	
Normal operation Short calibration time	tZQCS	128	-	128	-	128	-	128	-	nCK	
<b>Reset/Self Refresh Timing</b>											
Exit Reset from CKE HIGH to a valid command	tXPR	max (5nCK, tRFC(min)+ 10ns)	-	max (5nCK, tRFC(min)+ 10ns)	-	max (5nCK, tRFC(min)+ 10ns)	-	max (5nCK, tRFC(min)+ 10ns)	-		
Exit Self Refresh to commands not requiring a locked DLL	tXS	tRFC(min)+ 10ns	-	tRFC(min)+ 10ns	-	tRFC(min)+ 10ns	-	tRFC(min)+ 10ns	-		
SRX to commands not requiring a locked DLL in Self Refresh/ABORT	tX-S_ABORT(min)	tRFC4(min)+ 10ns	-	tRFC4(min)+ 10ns	-	tRFC4(min)+ 10ns	-	tRFC4(min)+ 10ns	-		
Exit Self Refresh to ZQCL, ZQCS and MRS (CL, CWL, WR, RTP and Gear Down)	tXS_FAST(min)	tRFC4(min)+ 10ns	-	tRFC4(min)+ 10ns	-	tRFC4(min)+ 10ns	-	tRFC4(min)+ 10ns	-		
Exit Self Refresh to commands requiring a locked DLL	tXSDLL	tDLLK(min)	-	tDLLK(min)	-	tDLLK(min)	-	tDLLK(min)	-		
Minimum CKE low width for Self refresh entry to exit timing	tCKESR	tCKE(min)+1 nCK	-	tCKE(min)+1 nCK	-	tCKE(min)+1 nCK	-	tCKE(min)+1 nCK	-		
Minimum CKE low width for Self refresh entry to exit timing with CA Parity enabled	tCKESR_PAR	tCKE(min)+ 1nCK+PL	-	tCKE(min)+ 1nCK+PL	-	tCKE(min)+ 1nCK+PL	-	tCKE(min)+ 1nCK+PL	-		

Speed		DDR4-1600		DDR4-1866		DDR4-2133		DDR4-2400		Units	NOTE
Parameter	Symbol	MIN	MAX	MIN	MAX	MIN	MAX	MIN	MAX		
Valid Clock Requirement after Self Refresh Entry (SRE) or Power-Down Entry (PDE)	tCKSRE	max(5nCK, 10 ns)	-	max(5nCK, 10 ns)	-	max(5nCK, 10 ns)	-	max(5nCK, 10 ns)	-		
Valid Clock Requirement after Self Refresh Entry (SRE) or Power-Down when CA Parity is enabled	tCKS-RE_PAR	max(5nCK, 10ns) +PL	-	max(5nCK, 10ns) +PL	-	max(5nCK, 10ns) +PL	-	max(5nCK, 10ns) +PL	-		
Valid Clock Requirement before Self Refresh Exit (SRX) or Power-Down Exit (PDX) or Reset Exit	tCKSRX	max(5nCK, 10 ns)	-	max(5nCK, 10 ns)	-	max(5nCK, 10 ns)	-	max(5nCK, 10 ns)	-		
<b>Power Down Timing</b>											
Exit Power Down with DLL on to any valid command; Exit Precharge Power Down with DLL frozen to commands not requiring a locked DLL	tXP	max(4nCK, 6ns)	-	max(4nCK, 6ns)	-	max(4nCK, 6ns)	-	max(4nCK, 6ns)	-		
CKE minimum pulse width	tCKE	max(3nCK, 5ns)	-	max(3nCK, 5ns)	-	max(3nCK, 5ns)	-	max(3nCK, 5ns)	-		31,32
Command pass disable delay	tCPDED	4	-	4	-	4	-	4	-	nCK	
Power Down Entry to Exit Timing	tPD	tCKE(min)	9*tREFI	tCKE(min)	9*tREFI	tCKE(min)	9*tREFI	tCKE(min)	9*tREFI		6
Timing of ACT command to Power Down entry	tACTPDEN	1	-	1	-	2	-	2	-	nCK	7
Timing of PRE or PREA command to Power Down entry	tPRPDEN	1	-	1	-	2	-	2	-	nCK	7
Timing of RD/RDA command to Power Down entry	tRDPDEN	RL+4+1	-	RL+4+1	-	RL+4+1	-	RL+4+1	-	nCK	
Timing of WR command to Power Down entry (BL8OTF, BL8MRS, BC4OTF)	tWRPDEN	WL+4+(tWR/tCK(avg))	-	WL+4+(tWR/tCK(avg))	-	WL+4+(tWR/tCK(avg))	-	WL+4+(tWR/tCK(avg))	-	nCK	4
Timing of WRA command to Power Down entry (BL8OTF, BL8MRS, BC4OTF)	tWRAPDEN	WL+4+WR+1	-	WL+4+WR+1	-	WL+4+WR+1	-	WL+4+WR+1	-	nCK	5
Timing of WR command to Power Down entry (BC4MRS)	tWRP-BC4DEN	WL+2+(tWR/tCK(avg))	-	WL+2+(tWR/tCK(avg))	-	WL+2+(tWR/tCK(avg))	-	WL+2+(tWR/tCK(avg))	-	nCK	4
Timing of WRA command to Power Down entry (BC4MRS)	tWRAP-BC4DEN	WL+2+WR+1	-	WL+2+WR+1	-	WL+2+WR+1	-	WL+2+WR+1	-	nCK	5
Timing of REF command to Power Down entry	tREFPDEN	1	-	1	-	2	-	2	-	nCK	7
Timing of MRS command to Power Down entry	tMRSPDEN	tMOD(min)	-	tMOD(min)	-	tMOD(min)	-	tMOD(min)	-		
<b>PDA Timing</b>											
Mode Register Set command cycle time in PDA mode	tMRD_PDA	max(16nCK, 10ns)		max(16nCK, 10ns)		max(16nCK, 10ns)		max(16nCK, 10ns)			
Mode Register Set command update delay in PDA mode	tMOD_PDA	tMOD		tMOD		tMOD		tMOD			
<b>ODT Timing</b>											
Asynchronous RTT turn-on delay (Power-Down with DLL frozen)	tAONAS	1.0	9.0	1.0	9.0	1.0	9.0	1.0	9.0	ns	
Asynchronous RTT turn-off delay (Power-Down with DLL frozen)	tAOFAS	1.0	9.0	1.0	9.0	1.0	9.0	1.0	9.0	ns	
RTT dynamic change skew	tADC	0.3	0.7	0.3	0.7	0.3	0.7	0.3	0.7	tCK(avg)	
<b>Write Leveling Timing</b>											
First DQS_t/DQS_n rising edge after write leveling mode is programmed	tWLMRD	40	-	40	-	40	-	40	-	nCK	12
DQS_t/DQS_n delay after write leveling mode is programmed	tWLDQSEN	25	-	25	-	25	-	25	-	nCK	12
Write leveling setup time from rising CK_t, CK_c crossing to rising DQS_t/DQS_n crossing	tWLS	0.13	-	0.13	-	0.13	-	0.13	-	tCK(avg)	
Write leveling hold time from rising DQS_t/DQS_n crossing to rising CK_t, CK_c crossing	tWLH	0.13	-	0.13	-	0.13	-	0.13	-	tCK(avg)	
Write leveling output delay	tWLO	0	9.5	0	9.5	0	9.5	0	9.5	ns	
Write leveling output error	tWLOE									ns	
<b>CA Parity Timing</b>											
Commands not guaranteed to be executed during this time	tPAR_UNKNOWN	-	PL	-	PL	-	PL	-	PL		



Speed		DDR4-1600		DDR4-1866		DDR4-2133		DDR4-2400		Units	NOTE
Parameter	Symbol	MIN	MAX	MIN	MAX	MIN	MAX	MIN	MAX		
Delay from errant command to ALERT_n assertion	tPAR_ALE R_T_ON	-	PL+6ns	-	PL+6ns	-	PL+6ns	-	PL+6ns		
Pulse width of ALERT_n signal when asserted	tPAR_ALE R_T_PW	48	96	56	112	64	128	72	144	nCK	
Time from when Alert is asserted till controller must start providing DES commands in Persistent CA parity mode	tPAR_ALER T_RSP	-	43	-	50	-	57	-	64	nCK	
Parity Latency	PL	4		4		4		5		nCK	
<b>CRC Error Reporting</b>											
CRC error to ALERT_nlatency	tCRC_ALER T	3	13	3	13	3	13	3	13	ns	
CRC ALERT_n pulsewidth	CRC_ALER T_PW	6	10	6	10	6	10	6	10	nCK	
<b>tREFI</b>											
tRFC1 (min) (1X mode)	2Gb	160	-	160	-	160	-	160	-	ns	34
	4Gb	260	-	260	-	260	-	260	-	ns	34
	8Gb	350	-	350	-	350	-	350	-	ns	34
	16Gb	550	-	550	-	550	-	550	-	ns	34
tRFC2 (min) (2X mode)	2Gb	110	-	110	-	110	-	110	-	ns	34
	4Gb	160	-	160	-	160	-	160	-	ns	34
	8Gb	260	-	260	-	260	-	260	-	ns	34
	16Gb	350	-	350	-	350	-	350	-	ns	34
tRFC4 (min) (4X mode)	2Gb	90	-	90	-	90	-	90	-	ns	34
	4Gb	110	-	110	-	110	-	110	-	ns	34
	8Gb	160	-	160	-	160	-	160	-	ns	34
	16Gb	260	-	260	-	260	-	260	-	ns	34

**Table 31: Timing Parameters by Speed Bin for DDR4-2666 to DDR4-3200**

Speed		DDR4-2666		DDR4-2933		DDR4-3200		Units	NOTE
Parameter	Symbol	MIN	MAX	MIN	MAX	MIN	MAX		
Minimum Clock Cycle Time (DLL off mode)	tCK (DLL_OFF)	8	20	8	20	8	20	ns	
Average Clock Period	tCK(avg)	0.750	<0.833	0.682	<0.750	0.625	<0.682	ns	35,36
Average high pulse width	tCH(avg)	0.48	0.52	0.48	0.52	0.48	0.52	tCK(avg)	
Average low pulse width	tCL(avg)	0.48	0.52	0.48	0.52	0.48	0.52	tCK(avg)	
Absolute Clock Period	tCK(abs)	tCK(avg) min + tJIT(per)min_to t	tCK(avg) max + tJIT(per)max_tot	tCK(avg) min + tJIT(per)min_to t	tCK(avg) max + tJIT(per)max_tot	tCK(avg) min + tJIT(per)min_to t	tCK(avg) max + tJIT(per)max_tot	tCK(avg)	
Absolute clock HIGH pulse width	tCH(abs)	0.45	-	0.45	-	0.45	-	tCK(avg)	23
Absolute clock LOW pulse width	tCL(abs)	0.45	-	0.45	-	0.45	-	tCK(avg)	24
Clock Period Jitter- total	JIT(per)_tot	-38	38	-34	34	-32	32	ps	25
Clock Period Jitter-deterministic	JIT(per)_dj	-19	19	-17	17	-16	16	ps	26
Clock Period Jitter during DLL locking period	tJIT(per, lck)	-30	30	-27	27	-25	25	ps	
Cycle to Cycle Period Jitter	tJIT(cc)	-	75	-	68	-	62	ps	
Cycle to Cycle Period Jitter during DLL locking period	tJIT(cc, lck)	-	60	-	55	-	50	ps	
Cumulative error across 2 cycles	tERR(2per)	-55	55	-50	50	-46	46	ps	
Cumulative error across 3 cycles	tERR(3per)	-66	66	-60	60	-55	55	ps	
Cumulative error across 4 cycles	tERR(4per)	-73	73	-66	66	-61	61	ps	
Cumulative error across 5 cycles	tERR(5per)	-78	78	-71	71	-65	65	ps	
Cumulative error across 6 cycles	tERR(6per)	-83	83	-75	75	-69	69	ps	
Cumulative error across 7 cycles	tERR(7per)	-87	87	-79	79	-73	73	ps	
Cumulative error across 8 cycles	tERR(8per)	-91	91	-83	83	-76	76	ps	
Cumulative error across 9 cycles	tERR(9per)	-94	94	-85	85	-78	78	ps	
Cumulative error across 10 cycles	tERR(10per)	-96	96	-88	88	-80	80	ps	
Cumulative error across 11 cycles	tERR(11per)	-99	99	-90	90	-83	83	ps	
Cumulative error across 12 cycles	tERR(12per)	-101	101	-92	92	-84	84	ps	
Cumulative error across 13 cycles	tERR(13per)	-103	103	-93	93	-86	86	ps	
Cumulative error across 14 cycles	tERR(14per)	-104	104	-95	95	-87	87	ps	

Speed		DDR4-2666		DDR4-2933		DDR4-3200		Units	NOTE
Parameter	Symbol	MIN	MAX	MIN	MAX	MIN	MAX		
Cumulative error across 15 cycles	tERR(15per)	-106	106	-97	97	-89	89	ps	
Cumulative error across 16 cycles	tERR(16per)	-108	108	-98	98	-90	90	ps	
Cumulative error across 17 cycles	tERR(17per)	-110	110	-100	100	-92	92	ps	
Cumulative error across 18 cycles	tERR(18per)	-112	112	-101	101	-93	93	ps	
Cumulative error across n = 13, 14 . . . 49, 50 cycles	tERR(nper)	$tERR(nper)_{min} = ((1 + 0.68\ln(n)) * tJIT(per)_{total min})$ $tERR(nper)_{max} = ((1 + 0.68\ln(n)) * tJIT(per)_{total max})$						ps	
Command and Address setup time to CK <sub>t</sub> , CK <sub>c</sub> referenced to Vih(ac) / Vil(ac) levels	tIS(base)	55	-	48	-	40	-	ps	
Command and Address setup time to CK <sub>t</sub> , CK <sub>c</sub> referenced to Vref levels	tIS(Vref)	145	-	138	-	130	-	ps	
Command and Address hold time to CK <sub>t</sub> , CK <sub>c</sub> referenced to Vih(dc) / Vil(dc) levels	tIH(base)	80	-	73	-	65	-	ps	
Command and Address hold time to CK <sub>t</sub> , CK <sub>c</sub> referenced to Vref levels	tIH(Vref)	145	-	138	-	130	-	ps	
Control and Address Input pulse width for each input	tIPW	385	-	365	-	340	-	ps	
CAS <sub>n</sub> to CAS <sub>n</sub> command delay for same bank group	tCCD <sub>L</sub>	max(5 nCK, 5 ns)	-	max(5 nCK, 5 ns)	-	max(5 nCK, 5 ns)	-	nCK	34
CAS <sub>n</sub> to CAS <sub>n</sub> command delay for different bank group	tCCD <sub>S</sub>	4	-	4	-	4	-	nCK	34
ACTIVATE to ACTIVATE Command delay to different bank group for 2KB page size	tRRD <sub>S</sub> (2K)	Max(4nCK, 5.3ns)	-	Max(4nCK, 5.3ns)	-	Max(4nCK, 5.3ns)	-	nCK	34
ACTIVATE to ACTIVATE Command delay to different bank group for 2KB page size	tRRD <sub>S</sub> (1K)	Max(4nCK, 3ns)	-	Max(4nCK, 2.7ns)	-	Max(4nCK, 2.5ns)	-	nCK	34
ACTIVATE to ACTIVATE Command delay to different bank group for 1/2KB page size	tRRD <sub>S</sub> (1/2K)	Max(4nCK, 3ns)	-	Max(4nCK, 2.7ns)	-	Max(4nCK, 2.5ns)	-	nCK	34
ACTIVATE to ACTIVATE Command delay to same bank group for 2KB page size	tRRD <sub>L</sub> (2K)	Max(4nCK, 6.4ns)	-	Max(4nCK, 6.4ns)	-	Max(4nCK, 6.4ns)	-	nCK	34
ACTIVATE to ACTIVATE Command delay to same bank group for 1KB page size	tRRD <sub>L</sub> (1K)	Max(4nCK, 4.9ns)	-	Max(4nCK, 4.9ns)	-	Max(4nCK, 4.9ns)	-	nCK	34
ACTIVATE to ACTIVATE Command delay to same bank group for 1/2KB page size	tRRD <sub>L</sub> (1/2K)	Max(4nCK, 4.9ns)	-	Max(4nCK, 4.9ns)	-	Max(4nCK, 4.9ns)	-	nCK	34
Four activate window for 2KB page size	tFAW <sub>2K</sub>	Max (28nCK, 30ns)	-	Max (28nCK, 30ns)	-	Max (28nCK, 30ns)	-	ns	34

Speed		DDR4-2666		DDR4-2933		DDR4-3200		Units	NOTE
Parameter	Symbol	MIN	MAX	MIN	MAX	MIN	MAX		
Four activate window for 1KB page size	tFAW_1K	Max (20nCK, 21ns)	-	Max (20nCK, 21ns)	-	Max (20nCK, 21ns)	-	ns	34
Four activate window for 1/2KB page size	tFAW_1/2K	Max (16nCK, 12ns)	-	Max (16nCK, 10.875ns)	-	Max (16nCK, 10ns)	-	ns	34
Delay from start of internal write transaction to internal read command for different bank group	tWTR_S	max (2nCK, 2.5ns)	-	max (2nCK, 2.5ns)	-	max (2nCK, 2.5ns)	-	ns	1,2, e,34
Delay from start of internal write transaction to internal read command for same bank group	tWTR_L	max (4nCK,7.5 ns)	-	max (4nCK,7.5 ns)	-	max (4nCK,7.5 ns)	-		1,34
Internal READ Command to PRECHARGE Command delay	tRTP	max (4nCK,7.5 ns)	-	max (4nCK,7.5 ns)	-	max (4nCK,7.5 ns)	-		34
WRITE recovery time	tWR	15	-	15	-	15	-	ns	1
Write recovery time when CRC and DM are enabled	tWR_CRC_DM	tWR+max (5nCK,3.7 5ns)	-	tWR+max (5nCK,3.7 5ns)	-	tWR+max (5nCK,3.7 5ns)	-	ns	1, 28
delay from start of internal write transaction to internal read command for different bank groups with both CRC and DM enabled	tWTR_S_CRC_DM	tWTR_S+ max (5nCK,3.7 5ns)	-	tWTR_S+ max (5nCK,3.7 5ns)	-	tWTR_S+ max (5nCK,3.7 5ns)	-	ns	2, 29,3 4
delay from start of internal write transaction to internal read command for same bank group with both CRC and DM enabled	tWTR_L_CRC_DM	tWTR_L+ max (5nCK,3.7 5ns)	-	tWTR_L+ max (5nCK,3.7 5ns)	-	tWTR_L+ max (5nCK,3.7 5ns)	-	ns	3, 30,3 4
DLL locking time	tDLLK	854	-	940	-	1024	-	nCK	
Mode Register Set command cycle time	tMRD	8	-	8	-	8	-	nCK	
Mode Register Set command update delay	tMOD	max(24nCK, 15ns)	-	max(24nCK, 15ns)	-	max(24nCK, 15ns)	-	nCK	50
Multi-Purpose Register Recovery Time	tMPRR	1	-	1	-	1	-	nCK	33
Multi Purpose Register Write Recovery Time	tWR_MPR	tMOD (min) + AL + PL	-	tMOD (min) + AL + PL	-	tMOD (min) + AL + PL	-	nCK	
Auto precharge write recovery + precharge time	tDAL(min)	Programmed WR + roundup ( tRP / tCK(avg))						nCK	
DQ0 or DQL0 driven to 0 set-up time to first DQS rising edge	tPDA_S	0.5	-	0.5	-	0.5	-	UI	45,4 7
DQ0 or DQL0 driven to 0 hold time from last DQS falling edge	tPDA_H	0.5	-	0.5	-	0.5	-	UI	46,4 7
<b>CS_n to Command AddressLatency</b>									
CS_n to Command Address Latency	tCAL	max(3 nCK, 3.748 ns)	-	max(3 nCK, 3.748 ns)	-	max(3 nCK, 3.748 ns)	-	nCK	

Speed		DDR4-2666		DDR4-2933		DDR4-3200		Units	NOTE
Parameter	Symbol	MIN	MAX	MIN	MAX	MIN	MAX		
<b>DRAM Data Timing</b>									
DQS_t, DQS_c to DQ skew, per group, per access	tDQSQ	-	0.18			-	TBD	tCK(av g)/2	13,1 8, 39, 49
DQ output hold time per group, per access from DQS_t, DQS_c	tQH	0.74	-	TBD	-	TBD	-	tCK(av g)/2	13,1 7,18 , 39, 49
<b>Data Strobe Timing</b>									
DQS_t, DQS_c differential READ Preamble (1 clock preamble)	tRPRE	0.9	NOTE 44	0.9	NOTE 44	0.9	NOTE 44	tCK	39, 40
DQS_t, DQS_c differential READ Preamble (2 clock preamble)	tRPRE2	1.8	NOTE 44	1.8	NOTE 44	1.8	NOTE 44	tCK	39, 41
DQS_t, DQS_c differential READ Postamble	tRPST	0.33	NOTE 45	0.33	NOTE 45	0.33	NOTE 45	tCK	39
DQS_t, DQS_c differential output high time	tQSH	0.4	-	0.4	-	0.4	-	tCK	21, 39
DQS_t, DQS_c differential output low time	tQSL	0.4	-	0.4	-	0.4	-	tCK	20, 39
DQS_t, DQS_c differential WRITE Preamble (1 clock preamble)	tWPRE	0.9	-	0.9	-	0.9	-	tCK	42
DQS_t, DQS_c differential WRITE Preamble (2 clock preamble)	tWPRE2	1.8	-	1.8	-	1.8	-	tCK	43
DQS_t, DQS_c differential WRITE Postamble	tWPST	0.33	-	0.33	-	0.33	-	tCK	
DQS_t and DQS_c low-impedance time (Referenced from RL-1)	tLZ(DQS)	-310	170	-280	165	-250	160	ps	39
DQS_t and DQS_c high-impedance time (Referenced from RL+BL/2)	tHZ(DQS)	-	170	-	165	-	160	ps	39
DQS_t, DQS_c differential input low pulse width	tDQSL	0.46	0.54	0.46	0.54	0.46	0.54	tCK	
DQS_t, DQS_c differential input high pulse width	tDQSH	0.46	0.54	0.46	0.54	0.46	0.54	tCK	

Speed		DDR4-2666		DDR4-2933		DDR4-3200		Units	NOTE
Parameter	Symbol	MIN	MAX	MIN	MAX	MIN	MAX		
DQS_t, DQS_c rising edge to CK_t, CK_c rising edge (1 clock preamble)	tDQSS	-0.27	0.27	-0.27	0.27	-0.27	0.27	tCK	42
DQS_t, DQS_c falling edge setup time to CK_t, CK_c rising edge	tDSS	0.18	-	0.18	-	0.18	-	tCK	
DQS_t, DQS_c falling edge hold time from CK_t, CK_c rising edge	tDSH	0.18	-	0.18	-	0.18	-	tCK	
DQS_t, DQS_c rising edge output timing location from rising CK_t, CK_c with DLL On mode	tDQSCK (DLL On)	-170	170	-165	165	-160	160	ps	37,3 8,39
Command path disable delay upon MPSM entry	tMPED	tMOD (MIN) + tCPDED (MIN)	-	TBD	TBD	TBD	TBD	nCK	
Valid clock requirement after MPSM entry	tCKMPE	tMOD (MIN) + tCPDED (MIN)	-	TBD	TBD	TBD	TBD	nCK	
Valid clock requirement before MPSM exit	tCKMPX	tCKSRX (MIN)	-	TBD	TBD	TBD	TBD	nCK	
Exit MPSM to commands not requiring a locked DLL	tXMP	tXS (MIN)	-	TBD	TBD	TBD	TBD	nCK	
Exit MPSM to commands requiring a locked DLL	tXMPDLL	tXMP (MIN) + tXSDLL (MIN)	-	TBD	TBD	TBD	TBD	nCK	
CS setup time to CKE	tMPX_S	tIS (MIN) + tIH (MIN)	-	TBD	TBD	TBD	TBD	ns	
CS_n High hold time to CKE rising edge	tMPX_HH	tXP	-	tXP	-	tXP	-	ns	
CS_n Low hold time to CKE rising edge	tMPX_LH	12	tXMP-10ns	12	tXMP-10ns	12	tXMP-10ns	ns	
Power-up and RESET calibration time	tZQinit	1024	-	1024	-	1024	-	nCK	
Normal operation Full calibration time	tZQoper	512	-	512	-	512	-	nCK	
Normal operation Short calibration time	tZQCS	128	-	128	-	128	-	nCK	
Exit Reset from CKE HIGH to a valid command	tXPR	max (5nCK, tRFC(min)+10 ns)	-	max (5nCK, tRFC(min)+10 ns)	-	max (5nCK, tRFC(min)+10 ns)	-	nCK	
Exit Self Refresh to commands not requiring a locked DLL	tXS	tRFC(min) +10ns	-	tRFC(min) +10ns	-	tRFC(min) +10ns	-	nCK	
SRX to commands not requiring a locked DLL in Self Refresh ABORT	tXS_ABO RT(min)	tRFC4(mi n)+ 10ns	-	tRFC4(mi n)+ 10ns	-	tRFC4(mi n)+ 10ns	-	nCK	

Speed		DDR4-2666		DDR4-2933		DDR4-3200		Units	NOTE
Parameter	Symbol	MIN	MAX	MIN	MAX	MIN	MAX		
Exit Self Refresh to ZQCL,ZQCS and MRS (CL,CWL,WR,RTP and Gear Down)	tXS_FAST (min)	tRFC4(min)+ 10ns	-	tRFC4(min)+ 10ns	-	tRFC4(min)+ 10ns	-	nCK	
Exit Self Refresh to commands requiring a locked DLL	tXSDLL	tDLLK(min)	-	tDLLK(min)	-	tDLLK(min)	-	nCK	
Minimum CKE low width for Self refresh entry to exit timing	tCKESR	tCKE(min)+ 1nCK	-	tCKE(min)+ 1nCK	-	tCKE(min)+ 1nCK	-	nCK	
Minimum CKE low width for Self refresh entry to exit timing with CA Parity enabled	tCKESR_PAR	tCKE(min)+ 1nCK+PL	-	tCKE(min)+ 1nCK+PL	-	tCKE(min)+ 1nCK+PL	-	nCK	
Valid Clock Requirement after Self Refresh Entry (SRE) or Power-Down Entry (PDE)	tCKSRE	max (5nCK, 10 ns)	-	max (5nCK, 10 ns)	-	max (5nCK, 10 ns)	-	nCK	
Valid Clock Requirement after Self Refresh Entry (SRE) or Power-Down when CA Parity is enabled	tCKSRE_PAR	max (5nCK, 10 ns)+PL	-	max (5nCK, 10 ns)+PL	-	max (5nCK, 10 ns)+PL	-	nCK	
Valid Clock Requirement before Self Refresh Exit (SRX) or Power-Down Exit (PDX) or Reset Exit	tCKSRX	max (5nCK, 10 ns)	-	max (5nCK, 10 ns)	-	max (5nCK, 10 ns)	-	nCK	
Exit Power Down with DLL on to any valid command;Exit Precharge Power Down with DLL frozen to commands not requiring a locked DLL	tXP	max (4nCK,6ns)	-	max (4nCK,6ns)	-	max (4nCK,6ns)	-	nCK	
CKE minimum pulse width	tCKE	max (3nCK, 5ns)	-	max (3nCK, 5ns)	-	max (3nCK, 5ns)	-	nCK	31,32
Command pass disable delay	tCPDED	4	-	4	-	4	-	nCK	
Power Down Entry to Exit Timing	tPD	tCKE(min)	9*tREFI	tCKE(min)	9*tREFI	tCKE(min)	9*tREFI	nCK	6
Timing of ACT command to Power Down entry	tACTPDEN	2	-	2	-	2	-	nCK	7
Timing of PRE or PREA command to Power Down entry	tPRPDEN	2	-	2	-	2	-	nCK	7
Timing of RD/RDA command to Power Down entry	tRDPDEN	RL+4+1	-	RL+4+1	-	RL+4+1	-	nCK	
Timing of WR command to Power Down entry (BL8OTF, BL8MRS, BC4OTF)	tWRPDEN	WL+4+(tWR/tCK(avg))	-	WL+4+(tWR/tCK(avg))	-	WL+4+(tWR/tCK(avg))	-	nCK	4
Timing of WRA command to Power Down entry (BL8OTF, BL8MRS, BC4OTF)	tWRAPDEN	WL+4+WR+1	-	WL+4+WR+1	-	WL+4+WR+1	-	nCK	5
Timing of WR command to Power Down entry (BC4MRS)	tWRPBC4DEN	WL+2+(tWR/tCK(avg))	-	WL+2+(tWR/tCK(avg))	-	WL+2+(tWR/tCK(avg))	-	nCK	4
Timing of WRA command to Power Down entry (BC4MRS)	tWRAPBC4DEN	WL+2+WR+1	-	WL+2+WR+1	-	WL+2+WR+1	-	nCK	5
Timing of REF command to Power Down entry	tREFPDEN	2	-	2	-	2	-	nCK	7

Speed		DDR4-2666		DDR4-2933		DDR4-3200		Units	NOTE
Parameter	Symbol	MIN	MAX	MIN	MAX	MIN	MAX		
Timing of MRS command to Power Down entry	tMRSPDEN	tMOD(min)	-	tMOD(min)	-	tMOD(min)	-	nCK	
Mode Register Set command cycle time in PDA mode	tMRD_PDA	max(16nCK, 10ns)	-	max(16nCK, 10ns)	-	max(16nCK, 10ns)	-	nCK	
Mode Register Set command update delay in PDA mode	tMOD_PDA	tMOD		tMOD		tMOD		nCK	
Asynchronous RTT turn-on delay (Power-Down with DLL frozen)	tAONAS	1.0	9.0	1.0	9.0	1.0	9.0	ns	
Asynchronous RTT turn-off delay (Power-Down with DLL frozen)	tAOFAS	1.0	9.0	1.0	9.0	1.0	9.0	ns	
RTT dynamic change skew	tADC	0.3	0.7	0.3	0.7	0.3	0.7	tCK(average)	
First DQS <sub>t</sub> /DQS <sub>n</sub> rising edge after write leveling mode is programmed	tWLMRD	40	-	40	-	40	-	nCK	12
DQS <sub>t</sub> /DQS <sub>n</sub> delay after write leveling mode is programmed	tWLDQSEN	25	-	25	-	25	-	nCK	12
Write leveling setup time from rising CK <sub>t</sub> , CK <sub>c</sub> crossing to rising DQS <sub>t</sub> /DQS <sub>n</sub> crossing	tWLS	0.13	-	0.13	-	0.13	-	tCK(average)	
Write leveling hold time from rising DQS <sub>t</sub> /DQS <sub>n</sub> crossing to rising CK <sub>t</sub> , CK <sub>c</sub> crossing	tWLH	0.13	-	0.13	-	0.13	-	tCK(average)	
Write leveling output delay	tWLO	0	9.5	0	9.5	0	9.5	ns	
Write leveling output error	tWLOE	0	2	0	2	0	2	ns	
Commands not guaranteed to be executed during this time	tPAR_UNKNOWN	-	PL	-	PL	-	PL	nCK	
Delay from errant command to ALERT <sub>n</sub> assertion	tPAR_ALERT_ON	-	PL+6ns	-	PL+6ns	-	PL+6ns	nCK	
Pulse width of ALERT <sub>n</sub> signal when asserted	tPAR_ALERT_PW	80	160	88	176	96	192	nCK	
Time from when Alert is asserted till controller must start providing DES commands in Persistent CA parity mode	tPAR_ALERT_RSP	-	71	-	78	-	85	nCK	
Parity Latency	PL	5		6		6		nCK	
CRC error to ALERT <sub>n</sub> latency	tCRC_ALERT	3	13	3	13	3	13	ns	
CRC ALERT <sub>n</sub> pulse width	CRC_ALERT_PW	6	10	6	10	6	10	nCK	



Speed		DDR4-2666		DDR4-2933		DDR4-3200		Units	NOTE
Parameter	Symbol	MIN	MAX	MIN	MAX	MIN	MAX		
Geardown setup time	tGEAR_setup	2	-			2	-	nCK	
Geardown hold time	tGEAR_hold	2	-			2	-	nCK	
tRFC1 (min) (1X mode)	2Gb	160	-	160	-	160	-	ns	34
	4Gb	260	-	260	-	260	-	ns	34
	8Gb	350	-	350	-	350	-	ns	34
	16Gb	550	-	550	-	550	-	ns	34
tRFC2 (min) (2X mode)	2Gb	110	-	110	-	110	-	ns	34
	4Gb	160	-	160	-	160	-	ns	34
	8Gb	260	-	260	-	260	-	ns	34
	16Gb	350	-	350	-	350	-	ns	34
tRFC4 (min) (4X mode)	2Gb	90	-	90	-	90	-	ns	34
	4Gb	110	-	110	-	110	-	ns	34
	8Gb	160	-	160	-	160	-	ns	34
	16Gb	260	-	260	-	260	-	ns	34

**NOTE :**

1. Start of internal write transaction is defined as follows :  
For BL8 (Fixed by MRS and on-the-fly) : Rising clock edge 4 clock cycles after WL. For BC4 (on-the-fly) : Rising clock edge 4 clock cycles after WL.  
For BC4 (fixed by MRS) : Rising clock edge 2 clock cycles after WL.
2. A separate timing parameter will cover the delay from write to read when CRC and DM are simultaneously enabled
3. Commands requiring a locked DLL are: READ (and RAP) and synchronous ODT commands.
4. tWR is defined in ns, for calculation of tWRPDEN it is necessary to round up tWR/tCK to the next integer.
5. WR in clock cycles as programmed in MR0.
6. tREFI depends on TCASE.
7. CKE is allowed to be registered low while operations such as row activation, precharge, autoprecharge or refresh are in progress, but power-down IDD spec will not be applied until finishing those operations.
8. For these parameters, the DDR4 SDRAM device supports  $t_{nPARAM}[nCK]=RU\{t_{PARAM}[ns]/t_{CK}(avg)[ns]\}$ , which is in clock cycles assuming all input clock jitter specifications are satisfied
9. When CRC and DM are both enabled, tWR\_CRC\_DM is used in place of tWR.
10. When CRC and DM are both enabled, tWTR\_S\_CRC\_DM is used in place of tWTR\_S.
11. When CRC and DM are both enabled, tWTR\_L\_CRC\_DM is used in place of tWTR\_L.
12. The max values are system dependent.
13. DQ to DQS total timing per group where the total includes the sum of deterministic and random timing terms for a specified BER. BER spec and measurement method are TBD.
14. The deterministic component of the total timing. Measurement method TBD.
15. DQ to DQ static offset relative to strobe per group. Measurement method TBD.
16. This parameter will be characterized and guaranteed by design.
17. When the device is operated with the input clock jitter, this parameter needs to be derated by the actual  $t_{jit(per)}_{total}$  of the input clock. (output deratings are relative to the SDRAM input clock). Example TBD.
18. DRAM DBI mode is off.
19. DRAM DBI mode is enabled. Applicable to x8 and x16 DRAM only.
20. tQSL describes the instantaneous differential output low pulse width on DQS\_t - DQS\_c, as measured from on falling edge to the next consecutive rising edge
21. tQSH describes the instantaneous differential output high pulse width on DQS\_t - DQS\_c, as measured from on falling edge to the next consecutive rising edge
22. There is no maximum cycle time limit besides the need to satisfy the refresh interval tREFI
23. tCH(abs) is the absolute instantaneous clock high pulse width, as measured from one rising edge to the following falling edge
24. tCL(abs) is the absolute instantaneous clock low pulse width, as measured from one falling edge to the following rising edge
25. Total jitter includes the sum of deterministic and random jitter terms for a specified BER. BER target and measurement method are TBD.
26. The deterministic jitter component out of the total jitter. This parameter is characterized and guaranteed by design.
27. This parameter has to be even number of clocks
28. When CRC and DM are both enabled, tWR\_CRC\_DM is used in place of tWR.
29. When CRC and DM are both enabled tWTR\_S\_CRC\_DM is used in place of tWTR\_S.
30. When CRC and DM are both enabled tWTR\_L\_CRC\_DM is used in place of tWTR\_L.
31. After CKE is registered LOW, CKE signal level shall be maintained below VILDC for tCKE specification ( Low pulse width ).
32. After CKE is registered HIGH, CKE signal level shall be maintained above VIHDC for tCKE specification ( HIGH pulse width ).
33. Defined between end of MPR read burst and MRS which reloads MPR or disables MPR function.
34. Parameters apply from  $t_{CK}(avg)_{min}$  to  $t_{CK}(avg)_{max}$  at all standard JEDEC clock period values as stated in the Speed Bin Tables.
35. This parameter must keep consistency with Speed-Bin Tables.
36. DDR4-1600 AC timing apply if DRAM operates at lower than 1600 MT/s data rate.  
 $UI=t_{CK}(avg)_{min}/2$
37. For MR7 commands, the minimum delay to a subsequent non-MRS command is 5nCK

## 7. DDR4 Function Matrix

DDR4 SDRAM has several features supported by ORG and also by Speed. The following Table is the summary of the features.

**Table 32: Function Matrix (By ORG. V:Supported, Blank: Not supported)**

Functions	x16	NOTE
Write Leveling	V	
Temperature controlled Refresh	V	
Low Power Auto Self Refresh	V	
Fine Granularity Refresh	V	
Multi Purpose Register	V	
Data Mask	V	
Data Bus Inversion	V	
TDQS		
ZQ calibration	V	
DQ Vref Training	V	
Per DRAM Addressability	V	
Mode Register Readout	V	
CAL	V	
WRITE CRC	V	
CA Parity	V	
Control Gear Down Mode	V	
Programmable Preamble	V	
Maximum Power Down Mode		
Boundary Scan Mode (CT Mode)	V	
Additive Latency		

**Table 33: Function Matrix (By Speed. V:Supported, Blank: Not supported)**

Functions	DLL Off mode	DLL On mode			NOTE
	equal or slower than 250Mbps	1600/1866/2133 Mbps	2400 Mbps	2666/3200 Mbps	
Write Leveling	V	V	V	V	
Temperature controlled Refresh	V	V	V	V	
Low Power Auto Self Refresh	V	V	V	V	
Fine Granularity Refresh	V	V	V	V	
Multi Purpose Register	V	V	V	V	
Data Mask	V	V	V	V	
Data Bus Inversion	V	V	V	V	
TDQS		V	V	V	
ZQ calibration	V	V	V	V	
DQ Vref Training	V	V	V	V	
Per DRAM Addressability		V	V	V	
Mode Register Readout	V	V	V	V	
CAL		V	V	V	
WRITE CRC		V	V	V	
CA Parity		V	V	V	
Control Gear Down Mode				V	
Programmable Preamble (= 2tCK)			V	V	
Maximum Power Down Mode		V	V	V	
Boundary Scan Mode (CT Mode)	V	V	V	V	

## 8. Package Drawing

### 8.1 96-ball FBGA- x16

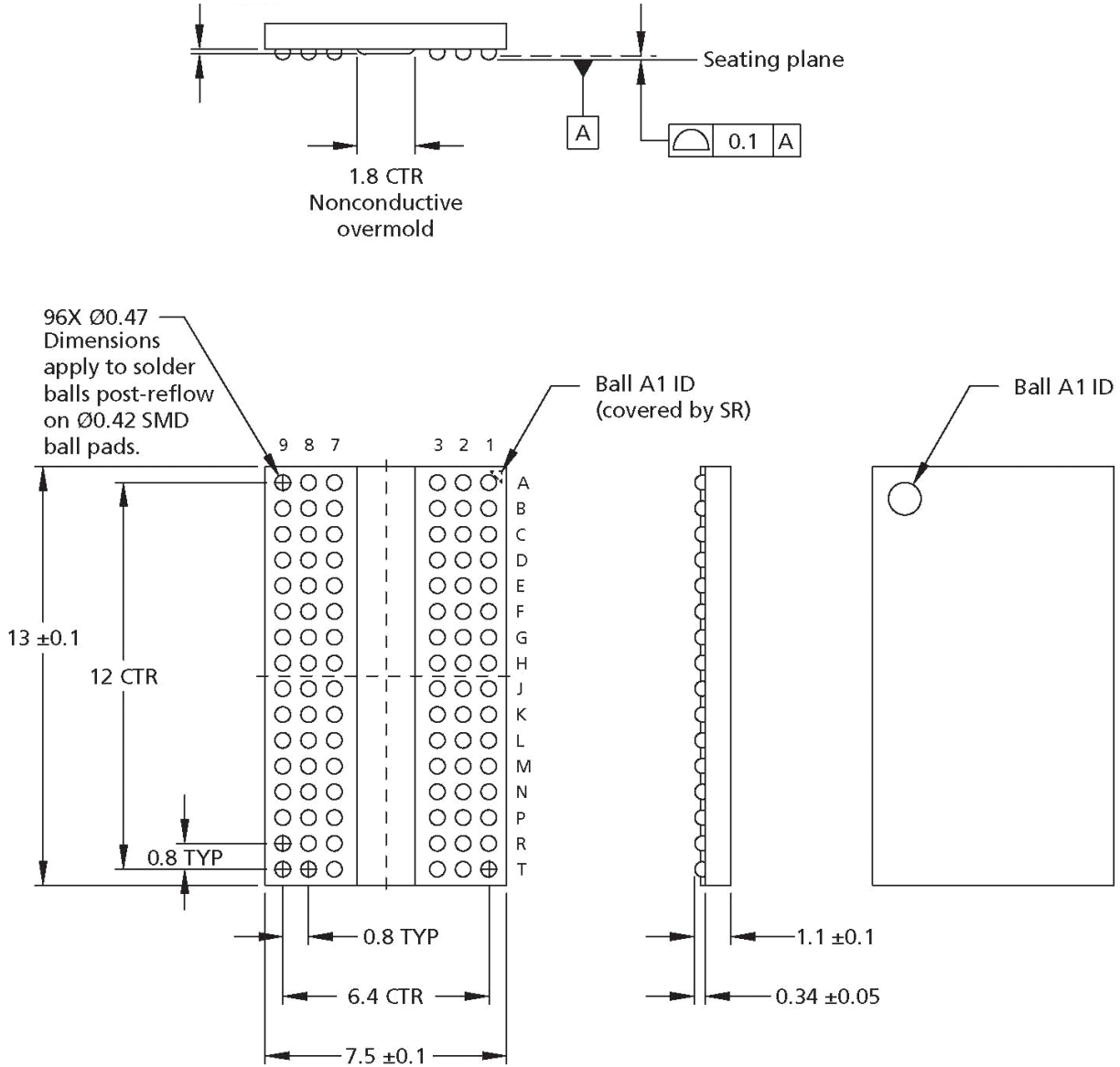

- Notes: 1. All dimensions are in millimeters.  
 2. Solder ball material: SAC302 (96.8% Sn, 3% Ag, 0.2% Cu).

**NOTES FOR CMOS DEVICES****① PRECAUTION AGAINST ESD FOR MOS DEVICES**

Exposing the MOS devices to a strong electric field can cause destruction of the gate oxide and ultimately degrade the MOS devices operation. Steps must be taken to stop generation of static electricity as much as possible, and quickly dissipate it, when once it has occurred. Environmental control must be adequate. When it is dry, humidifier should be used. It is recommended to avoid using insulators that easily build static electricity. MOS devices must be stored and transported in an anti-static container, static shielding bag or conductive material. All test and measurement tools including work bench and floor should be grounded. The operator should be grounded using wrist strap. MOS devices must not be touched with bare hands. Similar precautions need to be taken for PW boards with semiconductor MOS devices on it.

**② HANDLING OF UNUSED INPUT PINS FOR CMOS DEVICES**

No connection for CMOS devices input pins can be a cause of malfunction. If no connection is provided to the input pins, it is possible that an internal input level may be generated due to noise, etc., hence causing malfunction. CMOS devices behave differently than Bipolar or NMOS devices. Input levels of CMOS devices must be fixed high or low by using a pull-up or pull-down circuitry. Each unused pin should be connected to  $V_{DD}$  or GND with a resistor, if it is considered to have a possibility of being an output pin. The unused pins must be handled in accordance with the related specifications.

**③ STATUS BEFORE INITIALIZATION OF MOS DEVICES**

Power-on does not necessarily define initial status of MOS devices. Production process of MOS does not define the initial operation status of the device. Immediately after the power source is turned ON, the MOS devices with reset function have not yet been initialized. Hence, power-on does not guarantee output pin levels, I/O settings or contents of registers. MOS devices are not initialized until the reset signal is received. Reset operation must be executed immediately after power-on for MOS devices having reset function.

Change History

Rev. #	Who	When	What
01	SAE	2022-06-27	Initial version derived from DSA3F8GH40BBFZF.02

Important Notice:

Zentel products are not intended for medical implementation, airplane and transportation instrument, safety equipment, or any other applications for life support or where Zentel products failure could result in life loss, personal injury, or environment damage. Zentel customers who purchase Zentel products for use in such applications do so in their own risk and fully agree Zentel accepts no liability for any damage from this improper use.